

Valves & Manifolds

Valves &
Manifolds
Issue B.1

- Metal to metal body bonnet seal for high pressure and high temperature sealing.
- Unique non-rotating hardened tips – field interchangeable.
- 316 stainless steel trim.
- A 316 stainless steel pin eliminates unauthorised removal of bonnet assy.
- Materials of construction can be supplied to meet the requirements of NACE MR-01-75.
- Bubble tight metal-to-metal seat for positive shut off.
- Full material traceability of major components.
- Positive no slack stem action.
- 100% Hydrostatic testing.



Picture for reference only. Actual model may differ from model shown.



Picture for reference only. Actual model may differ from model shown.



Picture for reference only. Actual model may differ from model shown.

Product applications

The Valves & Manifolds are suitable for a wide range of applications in many

Industry sectors:

- Oil & Gas
- Chemical
- Power Generation
- Pharmaceutical
- Food & Beverage

The choice of models available ensures that the Valves & Manifolds are suitable for use in:

- Corrosive atmospheres
- Resistant to chemical attack

How can we help you?

Delta Controls' range of reliable pressure and temperature measurement instruments can be customised to meet individual requirements. For technical advice or to discuss your application please contact us on +44 (0) 20 8939 3500

V1 Model



Picture for reference only.
Actual model may differ
from model shown.

Needle Valves 6,000 psi & 10,000 psi

The precision made 'V1' model, single isolation hand valve utilising metal to metal seat and body to bonnet connection for superior, bubble tight sealing capabilities at both extreme pressures and temperatures. The "V1" model also offers non rotating hardened tip for extended service life. The unique anti vibration locking pin at the body bonnet connection is for extra safety. Working pressures are 6,000 psi and 10,000 psi. Maximum working temperature up to 240°C and up to 540°C with 004 option at reduced pressure.

Design Features

- Bubble tight metal to metal seat for positive shut off.
- Self centering & anti-galling non-rotating hardened tip for first time seal and long service life.
- Piston ring gives dynamic adjustable gland seal in response to pressure change.
- Metal to metal body bonnet seal for high pressure and high temperature sealing.
- Bonnet locking pin. No accidental removal of head unit, or loosening due to vibration.
- Bi-directional flow.
- Available NPT, BSPP, BSPT threaded and Socket weld.
- Maximum working temp 240°C (540°C with graphoil packing option 004)
- Anti-blow out spindle – a major safety feature.
- Secure seal-precision machined to give leak free operation for the life of the valve. Available in either PTFE or Graphoil.
- Full material traceability of major components.
- 100 % Hydrostatic testing.
- Materials of construction can be supplied to meet the requirements of NACE MR-01-75 latest revision.

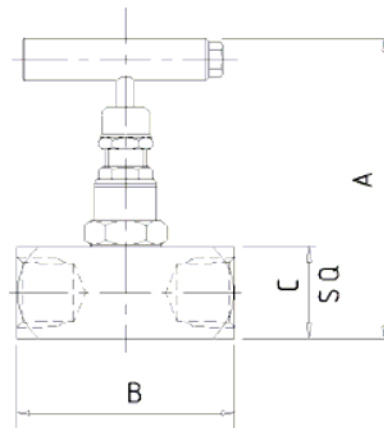

Part Numbers

St / St Part No	Connections size	A	B	C	Weight (kgs)
V1R1A1S	1/4" NPT	3.6	2.1	1.1	0.5
V1R2A1S	3/8" NPT	3.6	2.4	1.1	0.5
V1R3A1S	1/2" NPT	3.6	2.6	1.1	0.5
V1R4A1S	3/4" NPT	3.6	2.9	1.5	0.8
V1R5A1S	1" NPT	3.6	3.2	2.0	1.4

Dimensions in inches

This is not a comprehensive guide to all valves and manifolds available. If an option you require is not shown please contact Delta sales.

V2A Series



Picture for reference only. Actual model may differ from model shown.

2 Valve Manifold 6,000 psi and 10,000 psi rated

The two-valve isolating and venting manifold used mainly in gauge and static instrument applications such as pressure switches, pressure transmitters and manometers. The angled heads allow for panel mounting. The manifold will isolate instrumentation from the process and allow venting of the instrument for calibration / removal from the circuit without effecting the process / application and or recovery of a sample etc.

Incorporated are all the standard long service life features of the standard 'V1' model needle valve with multi-ring piston style packings. Safe anti-rotational pin locking device.

Design Features

- Angled heads allow panel mounting.
- Bubble tight metal to metal seat for positive shut off.
- Self centering & anti-galling non-rotating hardened tip for first time seal and long service life.
- Piston ring gives dynamic adjustable gland seal in response to pressure change.
- Metal to metal body bonnet seal for high pressure and high temperature sealing.
- Bonnet locking pin. No accidental removal of head unit, or loosening due to vibration.
- Bi-directional flow.
- Available NPT, BSPP, BSPT threaded and Socket weld.
- 1/4" NPT vent connection.
- Maximum working temp 240°C (540°C with graphoil packing option 004)
- Anti-blow out spindle – a major safety feature.
- Secure seal-precision machined to give leak free operation for the life of the valve. Available in either PTFE or Graphoil.
- Full material traceability of major components.
- 100 % Hydrostatic testing.
- Materials of construction can be supplied to meet the requirements of NACE MR-01-75 latest revision.
- 2 x 9/32" diameter mounting holes included.

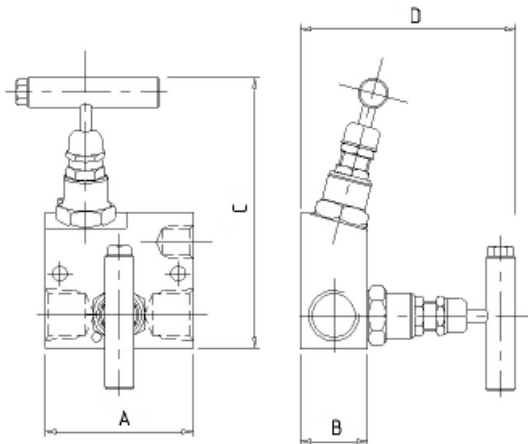

Part Numbers

St / St Part No	Connections Size	A	B	C	D	Weight (kgs)
V2A3A1S	1/2" NPT female x female	2.5	1.1	4.6	3.6	1.0

Dimensions in inches

This is not a comprehensive guide to all valves and manifolds available. If an option you require is not shown please contact Delta sales.

V2R Model

Picture for reference only.
Actual model may differ
from model shown.



In-line 2 Valve Manifold 6,000 psi and 10,000 psi rated

The "V2R" model 2 valve gauge manifold offering single process isolation and controlled venting. Unlike the 'V2A' model, the 'V2R' model can be offered with male inlet and female outlet connections. Available 6,000 psi and 10,000 psi versions, a slim-line and compact 2 valve manifold (vent port plugged as standard). The 'V2R' model, utilises metal to metal seat and body to bonnet connection for superior, bubble tight sealing capabilities at both extreme pressures and temperatures. The "V2R" model also offers non-rotating hardened tip for extended service life. The unique anti-vibration pin locking safety device at the body bonnet connection is for extra safety. Maximum working temperature up to 240°C and up to 540°C with 004 option at reduced pressure. Many options available including hand wheels and locking devices.

Design Features

- Bubble tight metal to metal seat for positive shut off.
- Self centering & anti-galling non-rotating hardened tip for first time seal and long service life.
- Piston ring gives dynamic adjustable gland seal in response to pressure change.
- Metal to metal body bonnet seal for high pressure and high temperature sealing.
- Bonnet locking pin. No accidental removal of head unit, or loosening due to vibration.
- Bi-directional flow.
- Available NPT, BSPP, BSPT threaded and Socket weld.
- 1/4" NPT vent connection.
- Maximum working temp 240°C (540°C with graphoil packing option 004)
- Anti-blow out spindle – a major safety feature.
- Secure seal-precision machined to give leak free operation for the life of the valve. Available in either PTFE or Graphoil.
- Full material traceability of major components.
- 100 % Hydrostatic testing.
- Materials of construction can be supplied to meet the requirements of NACE MR-01-75 latest revision.

V2R3A1S

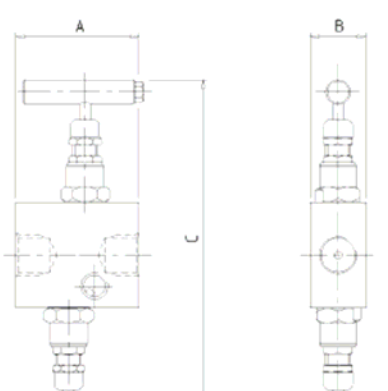

V2R3A2S

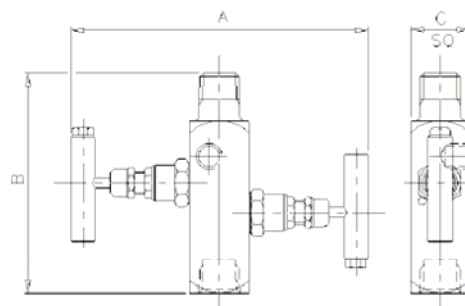

Part Numbers

St / St Part No	Connections	Size	A	B	C	Weight (kgs)
V2R3A1S	1/2" NPT female inlet x 1/2" NPT female outlet		2.5	1.1	7.1	0.9
V2R3A2S	1/2" NPT male inlet x 1/2" NPT female outlet		6.3	4.7	1.3	0.9

Dimensions in inches

This is not a comprehensive guide to all valves and manifolds available. If an option you require is not shown please contact Delta sales.

V2D Model



Direct Mount 2 Valve Manifold 6,000 psi rated

Two valve direct mount manifold, designed for use with pressure transmitters. The manifold will isolate instrumentation from the process and allow venting of the instrument for calibration / removal from the circuit without effecting the process / application and or recovery of a sample etc. This compact unit offers single isolation, and vent / test facility. Vent port 1/4" NPT (vent port plugged as standard for safety). Supplied with bolt pack and seal as standard. The V2D can be supplied with additional tapped holes in it's base for mounting purposes. Other options apply such as anti-tamper, lockable vent valve.

Design Features

- Bubble tight metal to metal seat for positive shut off.
- Self centering & anti-galling non-rotating hardened tip for first time seal and long service life.
- Piston ring gives dynamic adjustable gland seal in response to pressure change.
- Metal to metal body bonnet seal for high pressure and high temperature sealing.
- Bonnet locking pin. No accidental removal of head unit, or loosening due to vibration.
- Bi-directional flow.
- Available NPT, BSPP, BSPT threaded and Socket weld.
- 1/4" NPT vent connection.
- 2 x 5/16" UNF tapped mounting holes.
- Supplied with 7/16" UNF transmitter mounting bolts and seal rings.
- Maximum working temp 240°C (540°C with graphoil packing option 004)
- Anti-blow out spindle – a major safety feature.
- Secure seal-precision machined to give leak free operation for the life of the valve. Available in either PTFE or Graphoil.
- Full material traceability of major components.
- 100 % Hydrostatic testing.
- Materials of construction can be supplied to meet the requirements of NACE MR-01-75 latest revision.

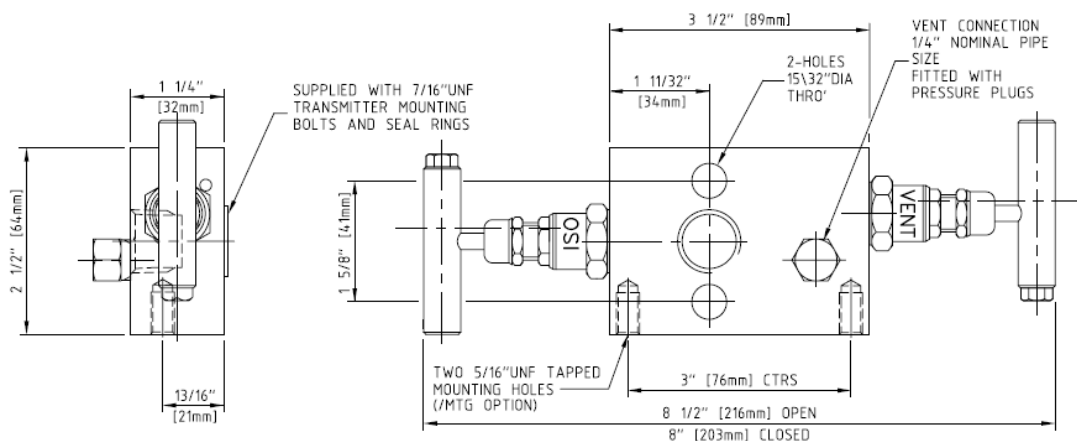

Part Numbers

St / St Part No	Connections Size	Weight (kgs)
V2D3A5S	1/2" NPT Female x flanged	1.4

Dimensions in inches

This is not a comprehensive guide to all valves and manifolds available. If an option you require is not shown please contact Delta sales.

V3R Model



Picture for reference only. Actual model may differ from model shown.

Remote Mount 3 Valve Manifold 6,000 psi and 10,000 psi Rated

The three-valve isolation manifold remote mounted (pipe to pipe). Used mainly in differential pressure transmitters and static instrument applications. The V3R has two process isolation valves and one equalisation valve to equalise the two sides. Standard 1/2" inlet x 1/2" outlet. Incorporated all the standard long service life features of the standard "V1" model needle valve with multi-ring piston style packings. Safe anti-rotational pin locking device. Most standard options such as locking devices are available. Process and instrument sides are both on 54mm (2 1/8") centres to correspond with transmitter connections.

Design Features

- 2 x isolation and 1 equalising valve for instrument balancing applications.
- Bubble tight metal to metal seat for positive shut off.
- Self centering & anti-galling non-rotating hardened tip for first time seal and long service life.
- Piston ring gives dynamic adjustable gland seal in response to pressure change.
- Metal to metal body bonnet seal for high pressure and high temperature sealing.
- Bonnet locking pin. No accidental removal of head unit, or loosening due to vibration.
- Bi-directional flow.
- Available NPT, BSPP, BSPT threaded and Socket weld.
- Maximum working temp 240°C (540°C with graphoil packing option 004)
- Anti-blow out spindle – a major safety feature.
- Secure seal-precision machined to give leak free operation for the life of the valve. Available in either PTFE or Graphoil.
- Full material traceability of major components.
- 100 % Hydrostatic testing.
- Materials of construction can be supplied to meet the requirements of NACE MR-01-75 latest revision.
- 2 x mounting holes as option

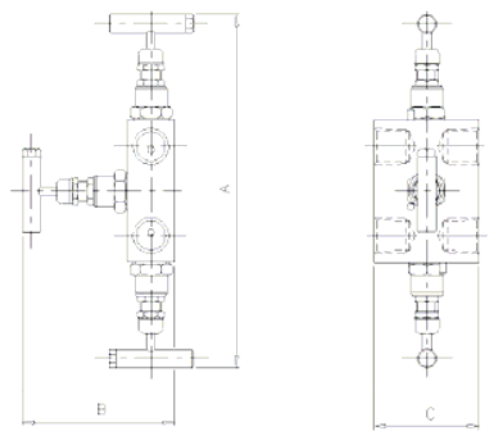

Part Numbers

St / St Part No	Connections Size	A	B	C	Weight (kgs)
V3R3A1S	2 x 1/2" NPT female x female	8.4	3.0	2.5	1.5

Dimensions in inches

This is not a comprehensive guide to all valves and manifolds available. If an option you require is not shown please contact Delta sales.

V3D Model

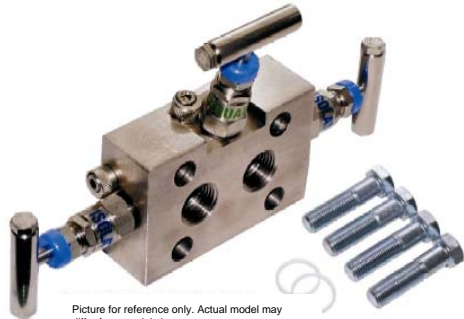

Direct Mount 3 Valve Manifold **6,000 psi rated**

Direct mounted three-valve manifold, instrument mount to pipe connection. Offering two isolation valves, and one equalising valve for differential pressure transmitter or static instrument applications. This slim, compact 3-valve manifold offers all the features of the V1's high integrity needle valve head design incorporated in one common instrument manifold block that mounts directly to an instrument.

Design Features

- Bubble tight metal to metal seat for positive shut off.
- Self centering & anti-galling non-rotating hardened tip for first time seal and long service life.
- Piston ring gives dynamic adjustable gland seal in response to pressure change.
- Metal to metal body bonnet seal for high pressure and high temperature sealing.
- Bonnet locking pin. No accidental removal of head unit, or loosening due to vibration.
- Bi-directional flow.
- Available NPT, BSPP, BSPT threaded and Socket weld.
- 4 x 7/16" UNF bolts for mounting to transmitter.
- 2 x PTFE/Graphoil seal rings for transmitter flange.
- Maximum working temp 240°C (540°C with graphoil packing option 004)
- Anti-blow out spindle – a major safety feature.
- Secure seal-precision machined to give leak free operation for the life of the valve. Available in either PTFE or Graphoil.
- Full material traceability of major components.
- 100 % Hydrostatic testing.
- Materials of construction can be supplied to meet the requirements of NACE MR-01-75 latest revision.
- ¼" NPT plugged vent connection option.

Part Numbers

St / St Part No	Connections Size	A	B	C	Weight (kgs)
V3D3A5S	2 x ½" NPT female x direct mount	4.7	8.6	1.2	1.5

Dimensions in inches

This is not a comprehensive guide to all valves and manifolds available. If an option you require is not shown please contact Delta sales.

V5D Series



Picture for reference only. Actual model may differ from model shown.

Direct mount 5 valve manifold **6,000 psi rated**

Direct style block mounted five-valve manifold, instrument mount to pipe connection. Offering two isolation valves, two vent valves and one equalising valve. Used in differential pressure transmitters and static instrument applications. Standard 2 x 1/2" inlet x direct mount with 2 x 1/4" plugged vent port supplied plugged. This slim, compact valve incorporates all the standard long service life features of the standard "V1" model needle valve with multi-ring piston style packings. Safe anti-rotational pin locking device. Most standard options such as locking devices are available. All additional ports supplied plugged as standard.

Design Features

- Bubble tight metal to metal seat for positive shut off.
- Self centering & anti-galling non-rotating hardened tip for first time seal and long service life.
- Piston ring gives dynamic adjustable gland seal in response to pressure change.
- Metal to metal body bonnet seal for high pressure and high temperature sealing.
- Bonnet locking pin. No accidental removal of head unit, or loosening due to vibration.
- Bi-directional flow.
- Available NPT, BSPP, BSPT threaded and Socket weld.
- 4 x 7/16" UNF bolts for mounting to transmitter.
- 2 x PTFE/Graphoil seal rings for transmitter flange.
- Maximum working temp 240°C (540°C with graphoil packing option 004)
- Anti-blow out spindle – a major safety feature.
- Secure seal-precision machined to give leak free operation for the life of the valve. Available in either PTFE or Graphoil.
- Full material traceability of major components.
- 100 % Hydrostatic testing.
- Materials of construction can be supplied to meet the requirements of NACE MR-01-75 latest revision.
- 1/4" NPT plugged vent connection option.

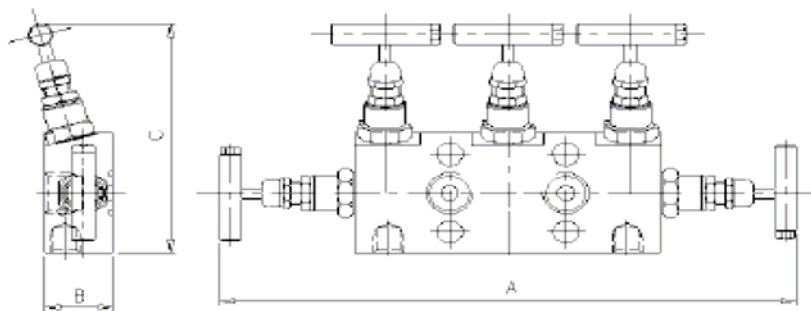

Part Numbers

St / St Part No	Connections Size	A	B	C	Weight (kgs)
V5D3A5S	2 x 1/2" NPT female x direct mount 2 x 1/4" NPT vents	10.6	1.3	4.8	2.3

Dimensions in inches

This is not a comprehensive guide to all valves and manifolds available. If an option you require is not shown please contact Delta sales.



Delta Controls Limited

Island Farm Avenue, West Molesey, Surrey KT8 2UZ, UK.

T+44 (0)20 8939 3500 F+44 (0)20 8783 1163 [E sales@delta-controls.com](mailto:sales@delta-controls.com) [W www.delta-controls.com](http://www.delta-controls.com)



FM0072n

