

## Diaphragm Operated Pressure Difference Switches: **Industrial S30 Series**

**S31 / 4  
Issue F**

- Field set point adjustment against a reference scale.
- SPDT or DPDT switching.
- Terminal block for easy field wiring.
- Hermetically sealed microswitch options.
- Optional gold alloy contacts.
- NACE MR-01-75 compatibility.
- Maximum working pressure up to 250 bar (3500 psi).
- Ranges available up to 10 bar (160 psi).
- Safety vented design as standard.
- Explosionproof NEMA 4, 4X, 7, 9
- Flameproof EEx d IIC - ATEX.

### Performance **characteristics**

#### Enclosure

- IP66 Protection

#### Wetted parts options

- 316 Stainless Steel diaphragm (standard)
- Suitable for NACE MR-01-75.
- Nitrile diaphragm and seal with aluminium or cast iron flanges (limited ranges)

#### Standard Electrical ratings – Refer to Table 6

- 1 Amp with gold contacts
- 5 Amps – general purpose, environmentally sealed & hermetically sealed.

#### Process connection

- Rc ¼ (BSP), ¼ NPT Internal, ½ NPT Internal & ½ NPT External.

#### Unit weight

- Between 4.0kg – 13.1kg (8.8lb – 29.9lb)

#### Accuracy

- Set point repeatability  $\pm 1\%$  of span at 20 °C / 68 °F ambient.



### Product **applications**

The S31/4 is suitable for a wide range of applications in many industry sectors:

- Oil & Gas
- Chemical
- Petrochemical
- Refining
- Power
- OEM

The choice of models available ensures that the S31/4 is suitable for use in:

- Corrosive atmospheres
- Resistant to chemical attack

### How can we **help you?**

Delta Controls' range of reliable pressure and temperature measurement instruments can be customised to meet individual requirements. For technical advice or to discuss your application please contact us on +44 (0) 20 8939 3500

## Enclosure

### FINISH

All enclosures except Type R, A and U are finished in light grey epoxy resin paint. Special finishes to order.

### INTRINSIC SAFETY

Because of the low voltages and currency of I.S. circuits, we recommend using gold and/or sealed contacts.







**NOTE:** *In the interests of safety and reliability not all enclosures are available with all wetted parts. See Table 4.*

**NOTE: Codes T and U** – to increase gas class see Table 6 NOTE 2.

**NOTE: Codes H, T for 4X**  
Aluminium Enclosure protected by quality epoxy paint system. Performance of enclosure required careful installation and sealing of cable gland connection in situ. Assembly requires to be built for Marine use, See Table 8, Code 02.

TABLE 1



FLAMEPROOF ENCLOSURES (ZONE 1)		Code
<b>EExd IIC T6(-60 to +65°C) T5 (-60 to+80°C)</b> Gravity die-cast enclosure in aluminium-silicon alloy, epoxy painted internally and externally certified to CENELEC EN 50 014 and EN50 018 II2GD. Weatherproof to NEMA type 4, 4X, IP66. See Note. 		H
<b>For Aggressive Atmospheres EExd IIC T6(-60 to +65°C) T5 (-60 to +80°C)</b> Investment cast enclosure in austenitic stainless steel certified to CENELEC EN 50 014 and EN50 018 II2GD. Weatherproof to NEMA type 4X, IP66. 		R
<b>Aluminium Alloy NEC 500, NEMA 7,9</b> Gravity die-cast enclosure in aluminium-silicon alloy. Class 1, Groups C and D, Class II, Groups E, F and G, Div. 1 & 2 Weatherproof to NEMA type 4, 4X, IP66. 		T
<b>For Aggressive Atmospheres NEC 500, NEMA 7,9</b> Investment cast enclosure in austenitic stainless steel. Class 1, Groups C and D, Class II, Groups E, F and G, Div.1 & 2. Weatherproof to NEMA type 4X, IP66. 		U
WEATHERPROOF ENCLOSURES		
<b>General Purpose</b> The basic enclosure is pressure die-cast in zinc alloy, epoxy painted, with weather protection not less than NEMA type 4, IP66.		W
<b>For Aggressive Atmospheres</b> Investment cast enclosure in austenitic stainless steel with weather protection not less than NEMA type 4X, IP66.		A
INTRINSIC SAFE ENCLOSURES		
<b>General Purpose Weatherproof EEx ia IIC T6 (-25 to +60°C) or T5 (-60 to +80°C)</b> The basic enclosure is pressure die-cast in zinc alloy, epoxy painted, with weather protection not less than NEMA type 4, IP66. 		5
<b>Weatherproof for Aggressive Atmosphere EEx ia IIC T6 (-25 to +60°C) or T5 (-60 to +80°C)</b> Investment cast enclosure in austenitic stainless steel with weather protection not less than NEMA type 4X, IP66. 		4

## Models

### S31

Maximum working pressure 1.0 bar (14.5 psi)/110 bar (1600 psi) see Table 5.

### S34

Maximum working pressure 250 bar (3,500 psi).

TABLE 2



	Code
<b>Fixed Switching Differential.</b> SPDT & DPDT options available. See Table 6.	S31
<b>Fixed Switching Differential</b> SPDT & DPDT options available. See Table 6.	S34



Applies to all models



## Electrical Entry

Adaptors are available for other popular thread sizes.



For codes 3 & 6 – see approvals and Table 1 Codes T & U



TABLE 3

	Code
Enclosure W: Clearance for 20mm (3/4 in) outside dia conduit.	1
Enclosure W: M20 x 1.5 elbow adaptor to suit.	0
Enclosure W: 3/4-NPT INT. elbow adaptor to suit.	3
Enclosures H, R & A: M20 x 1.5 ISO thread.	0
Enclosures H, R & A M20 x 1.5 ISO thread, dual entry.	5
Enclosures H, R, T & U: 3/4-NPT INT (direct)	3
Enclosures H, R, T & U: 3/4-NPT INT. dual entry	6

## Material of Wetted Parts

For aluminium flanges (Code D) select only from enclosures codes H, T and W. For Cast Iron flanges (Code E) select only from enclosure codes R, U or A. See Table 1



Applies to all materials



TABLE 4

Ranges		Code
BD-EA	316 Stainless steel diaphragm. All other wetted parts fully austenitic 300 series stainless steel, PTFE and Nitrile seals.	I
	For wetted parts required to conform with Sour Gas or Sour Crude, applications as laid down in NACE standard MR-01-75.	L
BC	Nitrile diaphragm and seal with aluminium flanges.	D
	Nitrile diaphragm and seal with cast iron flanges.	E

## Setting Ranges

When ordering, please state units required. Range and set point will be in units of preference. Unless otherwise stated, units will be in bar/mbar.

$P_{max}$  = maximum working pressure

The instruments will sustain, without loss of performance, a continuous forward over pressure equal to the maximum static pressure and/or full vacuum.

**NOTE:** For pressure difference switches maximum working pressure ( $P_{max}$ ) and maximum static/line pressure mean the same.

TABLE 5

Model	$P_{max}$		Range			Code
	bar	psi	mbar / bar	Code	in H <sub>2</sub> O / psi	
S31	1.0	14.5	<b>-12.5 to +12.5</b>	BC*	<b>-5.0 to +5.0</b>	BU*
S31 (S34)	110 (250)	1600 (3500)	<b>6 to 40</b>	BD (OD)	<b>2.5 to 16</b>	BY (OY)
S31 (S34)	110 (250)	1600 (3500)	<b>25 to 160</b>	CB (OB)	<b>10 to 64</b>	CS (IS)
S31 (S34)	110 (250)	1600 (3500)	<b>100 to 600</b>	CE (OE)	1.5 to 8.5	CK (OK)
S31 S34	110 250	1600 3500	0.4 to 2.5	DC	6 to 40	DP
S31 S34	110 250	1600 3500	0.6 to 4	DD	10 to 60	DT
S31 S34	110 250	1600 3500	1.6 to 10	EA	25 to 160	EH

\* Forward overpressure is limited to 500 mbar



Applies to all ranges above

Maximum static/line pressure applied in the reverse direction (i.e., to low pressure connection with high pressure connection open to atmosphere) will be contained without failure. The diaphragm on ranges BD to EA (BY to EH) will however have been distorted, leading to a degradation of performance and a shortening of the service life.

For applications where regular reversals of pressure are inevitable, a special engineering facility is available, see Table 9.

## Switching Options

**TABLE 6**

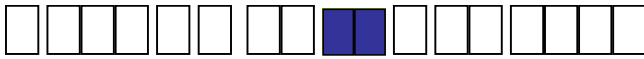

<b>Model S31 / 4</b>									
UL/CSA Rating (RESISTIVE) §SEE NOTE	IEC 947-5-1/EN 60947-5-1 Rating							Contact	Code
	Designation & Utilization Category	Rated operational current I <sub>e</sub> (A) at rated operational voltage U <sub>e</sub>	U <sub>i</sub>	U <sub>imp</sub>	VA Rating				
					Make	Break			
5 Amps @ 110/250V AC Light Duty for AC only	AC14 D300	0.6/0.3A @ 120/240V AC	250V	0.8kV	432	72	SPDT DPDT	00 01	
	DC13 R300	0.22/0.1A @ 125/250V DC			28	28			
5 Amps @ 110/250V AC & 2 Amps @ 30V DC General purpose precision	AC14 D300	0.6/0.3A @ 120/240V AC	250V	0.8kV	432	72	SPDT DPDT	02 03	
	DC13 R300	0.22/0.1A @ 125/250V DC			28	28			
1 Amp @ 125V AC & §100mA @ 30V DC gold alloy contacts for low voltage switching	1 A @ 125 VAC RESISTIVE (IEC 1058-1/EN 61058-1)						SPDT DPDT	04 05	
§ 5 Amps @ 110/250V AC & 5 Amps @ 30V DC Environmentally sealed.	AC14 D300	0.6/0.3A @ 120/240V AC	250V	0.5kV	432	72	SPDT* DPDT*	08 09	
	DC13 R300	0.22/0.1A @ 125/250V DC			28	28			
§ 1 Amp @ 30V AC & 30V DC Environmentally sealed with gold contacts	AC14 E150	0.3A @ 120V AC	125V	0.5kV	216	36	SPDT* DPDT*	0G 0H	
5 Amps @ 250V AC and 2 Amps @ 30V DC Hermetically sealed. Gold plated silver contacts.	AC14 D300	0.6/0.3A @ 120/240V AC	250V	0.5kV	432	72	SPDT DPDT	H2 H3†, H6‡	
	DC13 R300	0.22/0.1A @ 125/250V DC			28	28			

† 2 Single pole, double throw, simultaneous falling under pressure      00, 01, 02, 03, 04 & 05 microswitches

‡ 2 Single pole, double throw, simultaneous rising under pressure.

**NOTE 1 :** Enclosure Codes T and U.      Enclosure Codes H and R  
Microswitch Codes 02 and 03      Microswitch Codes 02 and 03  
UL/CSA rating as follows:-      UL/CSA rating as follows:-  
110/250V AC 5A 250V/125V DC 0.25/0.5A      110/250V AC 5A 250V/125/30V DC 0.25/0.5/2A

**NOTE 2 :** Using codes H2, H3, H6 increases the Gas Class to:  
Class 1, Groups A, B, C and D, Div 2, for Enclosures T and U.

H2, H3 † & H6‡ microswitches  
  
UL recognised component for use in Hazardous areas  
Class 1, Div 2, Groups A, B, C, D. Class II Groups F  
and G. When used in enclosure T and U

00, 01, 02, 03, 04, 05, H2, H3† & H6‡ microswitches  
  
CSA accepted component for use in hazardous  
areas Class 1, Div 2, Groups A, B, C, D.  
When used in enclosures T and U.

The electrical rating is dependent on the microswitch fitted to the instrument. The electrical ratings defined by each approval that the microswitch complies with and is shown on the product nameplate, ie UL/CSA, or IEC. It should be noted that the instrument must be used within the electrical rating specified from the approval you require. This table lists the actual IEC ratings against the Designation & Utilization Category marked on the nameplates. In the absence of any verification by UL/CSA the microswitch § manufacturer's rating is stated in **italics and bold**. **If in doubt seek guidance from the factory.**

**NOTE:** For low energy circuits e.g. 30V and up to 100mA, we recommend using gold alloy contact switches.  
U<sub>i</sub> = rated insulation voltage      U<sub>imp</sub> = rated impulse withstand voltage across contacts.

## Process Connection

**TABLE 7**

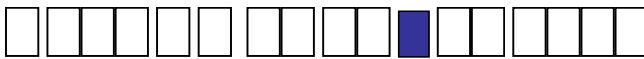

**NOTE:** Range code BC (BU) can only be supplied with integral Rc1/4 or 1/4 NPT process connections. For other thread sizes specify adaptors.

**NOTE:** Range code BC/BU for CSA or UL can only be supplied with process connections Code A or F.



For Code A, F, H, J



	Code
Rc 1/4 (1/4 BSP tr INT) to (ISO 7/1)	A
1/4 – 18NPT INT	F
1/2 – 14NPT INT	H
1/2 – 14NPT EXT	J

## Options & Treatments

TABLE 8

	Code
Tropicalisation High humidity environment	01*
Marine and Offshore Saline atmosphere or salt spray	02*
Ammonia Process (wetted) parts and construction suitable for atmospheric ammonia.	03
Oxygen Service 2: Process (wetted) parts are cleaned for oxygen.	04*
Oxygen Service3: Process and non-process parts are cleaned for use with oxygen.	05*
Stainless Steel Pipe Mounting Bracket Permits local 2" pipe work to be utilised for mounting the instrument.	10
Tagging - Variety of tagging methods are available	APPLY FOR DETAILS
Applies when – no option is required and selection is made from special engineering.	00

Combinations available, apply for details.

\* Not available on range BC/BU

## Special Engineering

TABLE 9

FEATURE	Code
Please consult Delta sales engineering for special requirements.	TBA



Refer to engineering



## Performance Data

TABLE 10

### Bar Units (SI)

#### FIXED SWITCHING DIFFERENTIAL

Due to manufacturing tolerances, the figures quoted in these tables are for guidance only. Should the differential be critical for specific applications, our engineers should be consulted prior to ordering.

Code	Range mbar / bar	$P_{max}$ Bar	Model	Microswitch – Option Switching Differential Mbar									
				00	01	02	03	04	05	08/0G	09/0H	H2	H3/H6
BC	12.5 to 12.5	1	S31	0.6	1	2	2.5	1	1.5	1.8	2.4	2.4	2.4
BD	6 to 40	110 250	S31 S34	1.3	2	4	6	2	3	8	11	10	10
CB	25 to 160	110 250	S31 S34	2.6	4	9	12	4	6	16	21	18	21
CE	100 to 600	110 250	S31 S34	3.3	5	12	15	6	9	20	27	30	32
DC	0.4 to 2.5	110 250	S31 S34	50	75	120	160	70	100	300	400	200	270
DD	0.6 to 4	110 250	S31 S34	60	90	210	270	90	140	360	480	350	480
EA	1.6 to 10	110 250	S31 S34	120	180	420	540	180	250	720	960	800	1200

### PSI Units

Code	Range ins H <sub>2</sub> O / psi	$P_{max}$ Psi	Model	Microswitch – Option Switching Differential Ins H <sub>2</sub> O / Psi									
				00	01	02	03	04	05	08/0G	09/0H	H2	H3/H6
BU	-5.0 to +5.0	14.5	S31	0.2	0.4	0.8	1.0	0.4	0.6	0.7	0.9	0.9	0.9
BY	2.5 to 16	1600 3500	S31 S34	0.5	0.9	1.6	2.3	0.8	1.2	3.1	4.3	3.9	3.9
CS	10 to 64	1600 3500	S31 S34	1.0	1.6	3.5	4.7	1.6	2.3	6.2	8.2	7.2	8.2
CK	1.5 to 8.5	1600 3500	S31 S34	0.05	0.07	0.17	0.21	0.08	0.13	0.29	0.39	0.43	0.46
DP	6 to 40	1600 3500	S31 S34	0.72	1.1	1.7	2.3	1.0	1.4	4.3	5.8	2.9	3.9
DT	10 to 60	1600 3500	S31 S34	0.87	1.3	3.0	3.9	1.3	2.0	5.2	7.0	5.1	7.0
EH	25 to 160	1600 3500	S31 S34	1.7	2.6	6.1	7.8	2.6	3.6	10.4	13.9	11.6	17.4

## Technical Specifications

### ACCURACY

Set point repeatability  $\pm 1\%$  of span at 20°C ambient.

### AMBIENT TEMPERATURE RANGE

For continuous use below  $-25^{\circ}\text{C}$  ( $-13^{\circ}\text{F}$ ) we recommend using only enclosures H, R, T, U and A with special gaskets and limited switching.

### MAXIMUM PROCESS TEMPERATURE

Subject to appropriate installation practice, the component parts withstand up to  $+60^{\circ}\text{C}$  ( $+140^{\circ}\text{F}$ ).

### ELECTRICAL CONNECTIONS

#### Terminal Block

Cable entry is to a non-pinching terminal block made of a non-hygroscopic thermosetting plastic, suitable for cables up to  $2.5\text{mm}^2/14\text{AWG}$ .

#### Earthing/Grounding

An earthing facility is provided inside all weatherproof enclosures, adjacent to the entry. External earthing is standard on flameproof versions.

### Dielectric Strength

The electrical assembly is capable of withstanding  $\ast 2\text{kV}$  between live parts and earth/ground and 500V between open contacts.

$\ast 1.2\text{kV}$  for micro switch Codes H2, H3 and H6. Refer to Table 6.

### Electrical Entry

Standard options are listed in Table 3. Other threads can be accommodated by adaptors. Dual entry available, see Table 3. **OPTIONAL EXTRAS**

### Chemical Seals

Chemical seals of our own or proprietary manufacture can be fitted when required.

UNIT WEIGHTS (Approx)					
	MODEL S31			MODEL S34	
Range Codes	BC	BD/CB/CE	DC/DD/EA	BD/CB/CE	DC/DD/EA
'H, T' Enclosures	4.0kg/8.8lb	6.3kg/13.9lb	4.2kg/9.3lb	8.6kg/19.0lb	6.5kg/14.2lb
'R, U' Enclosures	11.5kg/25.4lb	10.8kg/23.8lb	8.7kg/19.2lb	13.1kg/29.9lb	11.0kg/24.1lb
'W' Enclosure	4.0kg/8.8lb	6.3kg/13.9lb	4.2kg/9.3lb	8.6kg/19.0lb	6.5kg/14.3lb
'A' Enclosure	8.3kg/18.3lb	7.6kg/16.7lb	5.5kg/12.1lb	9.9kg/21.8lb	7.8kg/17.2lb

## Operation / Installation



### Mounting position / Location / Installation.

Vertical as shown, taking care to avoid sitting in locations that transmit excessive shock or vibration. For further advice contact our engineers

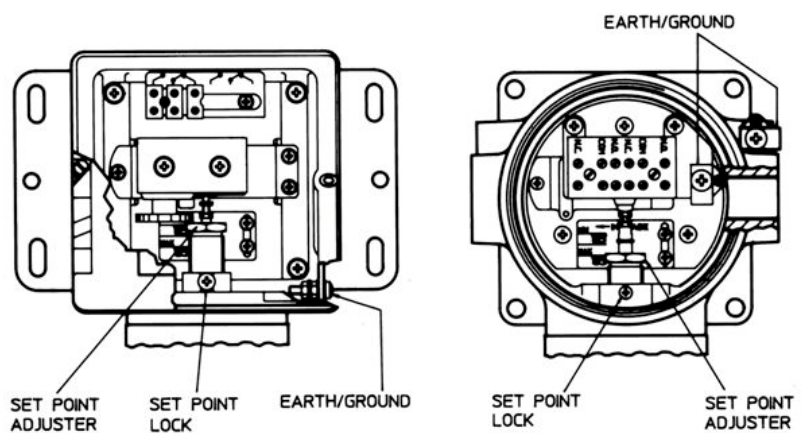
### TYPICAL INTERNAL ARRANGEMENT



## Approvals

<b>INTRINSIC SAFETY</b>	Because of the low voltages and currents of intrinsically safe circuits, we recommend using gold contacts. Refer to Table 6.	
<b>CENELEC/ATEX II 2 G D</b>	Certified to CENELEC EN50 014 and EN50 018. For use in Zone 1 hazardous areas EEx d IIC T6 (-60° to +65°C) T5 (-60° to +85°C) Enclosure Codes H and R and all models (see Table 1) Certificate number BASEEFA 01ATEX2113X	
<b>UNDERWRITER LABORATORIES INC.</b>	Snap switches for use in Hazardous Locations. Class 1, Groups A, B, C, D Class II, Groups E, F, G Division 1 and 2 E136771	
<b>CANADIAN STANDARDS ASSOCIATION</b>	Snap switches for use in Hazardous Locations. Class 1, Groups A, B, C, D Class II, Groups E, F, G Division 1 and 2 LR94185	

## Dimensions

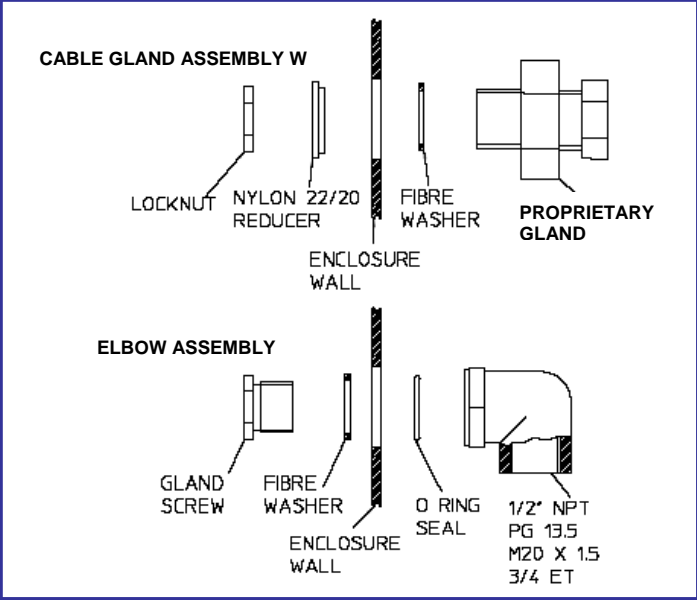

# Dimensions

All dimensions mm (inches)

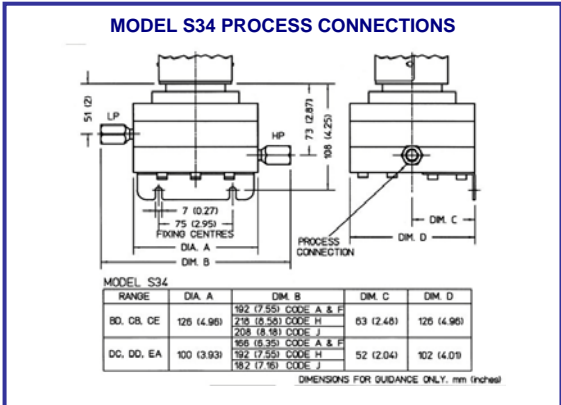
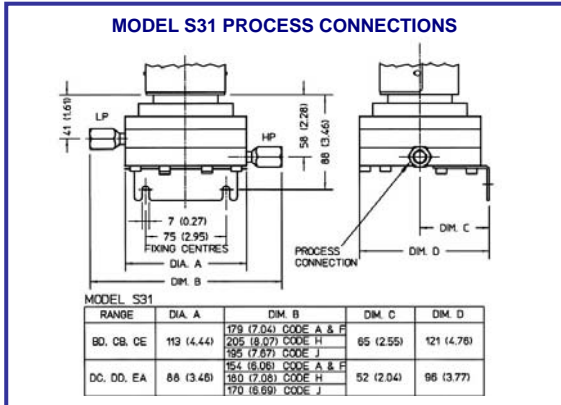
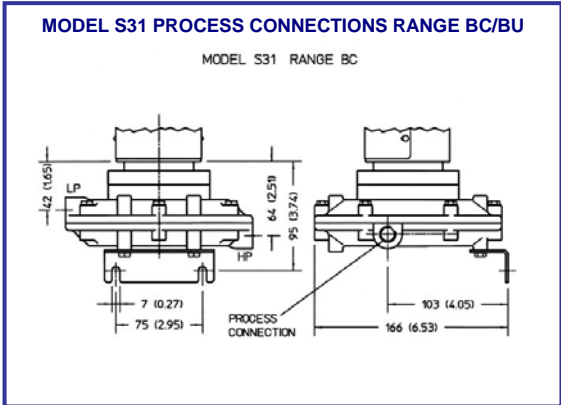
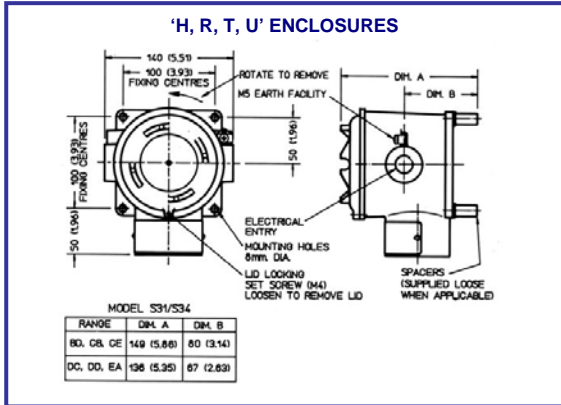
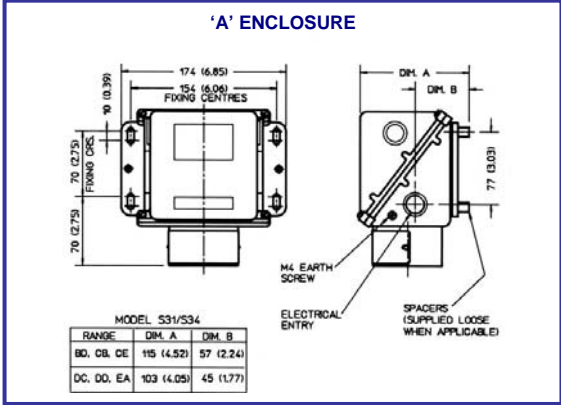
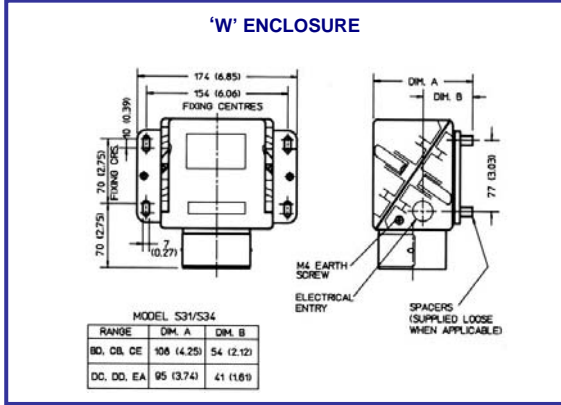

In the interest of development and improvement Delta Controls Ltd, reserves the right to amend, without notice, details contained in this publication. Delta Controls Ltd will accept no legal liability for any errors, omissions or amendments.



**Delta Controls Limited**

Island Farm Avenue, West Molesey, Surrey KT8 2UZ, UK.

T+44 (0)20 8939 3500 F+44 (0)20 8783 1163 E [sales@delta-controls.com](mailto:sales@delta-controls.com) W [www.delta-controls.com](http://www.delta-controls.com)



FM00720