

Diaphragm Operated Pressure Switches **Industrial S20 Series**

- Ranges available up to 700 bar (10,000 psi)
- Maximum working pressure up to 1000 bar (15,000 psi)
- Epoxy coated die cast zinc / aluminium and stainless steel
- Weatherproof enclosures NEMA 4, 4X, IP66
- Explosionproof enclosures NEMA 4, 4X, 7, 9
- Flameproof Eex d IIC - ATEX
- Safety vented design as standard
- Field set point adjustment against a reference scale
- SPDT or DPDT switching and optional gold alloy contacts
- Terminal block for easy field wiring
- Hermetically sealed microswitch options
- 316 stainless steel wetted parts
- NACE MR-01-75 compatibility
- PED 97/23/EC CAT IV option

Performance **characteristics**

Enclosure

- IP66 Protection

Wetted parts options

- 316 Stainless Steel (welded and with Viton / Nitrile O rings)
- Nickel Alloy (Monel)

Standard Electrical ratings – Refer to Table 6

- 5 Amps – general purpose, environmentally sealed, hermetically sealed
- 1 Amp with gold contacts.

Process connection

- Rc ¼ (BSP), ¼ NPT Internal, ½ NPT Internal & ½ NPT External

Unit weight

- Between 2.7kg – 6.6kg (5.9lb – 14.5lb)

Accuracy

- Set point repeatability $\pm 1\%$ of span at 20 °C / 68 °F ambient



Product **applications**

The **S20 series** is suitable for a wide range of applications in many industry sectors:

- Oil & Gas
- Chemical
- Petrochemical
- Refining
- Power
- OEM

The choice of models available ensures that the **S20 series** is suitable for use in:

- Corrosive atmospheres
- Resistant to chemical attack

How can we **help you?**

Delta Controls offers fast, efficient and knowledgeable support when and where you need it. Please visit our web site at www.delta-controls.com to find your local support centre or call us on

+44 (0) 20 8939 3500

Enclosure

TABLE 1



INTRINSIC SAFETY

Because of the low voltages and currency of I.S. circuits, we recommend using gold and/or sealed contacts.

Temperatures in Table 1 refer to limitations for certified enclosures. See **TECHNICAL DATA**.

NOTE: Codes T and U – to increase gas class see Table 6 NOTE 2.

NOTE: Codes H, 2 & T for 4X











Aluminium Enclosure protected by quality epoxy paint system. Performance of enclosure requires careful installation and sealing of cable gland connection in situ. Assembly requires to be built for Marine use, See Table 8, Code 02.

NOTE: Codes 3 and 2

To be used on S24 only with S or T wetted parts.

NOTE: Codes 4 and 5.

To be used only on switch codes 04/05, 0G/0H, H2/H3/H6. See Table 6. PED Cat IV not available at present.

FLAMEPROOF ENCLOSURES	Code
ZONE 1 ATEX EExd IIC T6(-60 to +65°C) T5 (-60 to+80°C) Gravity die-cast enclosure in aluminium-silicon alloy, epoxy painted internally and externally certified to CENELEC EN 50 014 and EN50 018.  II 2GD Weatherproof to NEMA 4X, IP66. See Note.	H
ZONE 1 ATEX For Aggressive Atmospheres EExd IIC T6(-60 to +65°C) T5 (-60 to+80°C) Investment cast enclosure in austenitic stainless steel certified to CENELEC EN 50 014 and EN50 018 . Weatherproof to NEMA type 4X, IP66.  II 2GD	R
ZONE 0 / 1 ATEX Flameproof Stainless Steel Cat 1 / 2 (S24 only) Connected to a process system classified as EEx d IIC certified to CENELEC standards – EN50284.  II 1/2GD Weather Protection IP66/NEMA 4X investment cast in austenitic stainless steel.	2
ZONE 0 / 1 ATEX Flameproof Aluminium Alloy Cat 1 / 2 (S24 only) Connected to a process system classified as EEx d IIC certified to CENELEC standards – EN50284.  II 1/2GD Weather protection IP66/NEMA 4X. Gravity die-cast in Aluminium LM25.	3
NEC 500, NEMA 7,9 Aluminium Alloy Gravity die-cast enclosure in aluminium-silicon alloy, epoxy painted internally and externally.   Weatherproof to NEMA 4X, IP66. See Note.	T
NEC 500, NEMA 7,9 For Aggressive Atmospheres Investment cast enclosure in austenitic stainless steel.   Class 1, Groups C and D, Class II, Groups E, F and G, Div.1 & 2. Weatherproof to NEMA type 4X, IP66.	U
WEATHERPROOF ENCLOSURES	
General Purpose The basic enclosure is pressure die-cast in zinc alloy, epoxy painted, with weather protection not less than NEMA type 4, IP66.	W
For Aggressive Atmospheres Investment cast enclosure in austenitic stainless steel with weather protection not less than NEMA 4X, IP66.	A
INTRINSICALLY SAFE ENCLOSURES	
ATEX ZONE 0 General Purpose  II 1 GD EEx ia IIC T6 (-25°C ≤ T _a ≤ +60°C) or T5 (-60°C ≤ T _a ≤ +80°C) certified to CENELEC standards. Weather Protection IP66/NEMA 4 Pressure die-cast in Zinc with light grey epoxy paint.	5
ATEX ZONE 0 For Aggressive Atmosphere  II 1 GD EEx ia IIC T6 (-25°C ≤ T _a ≤ +60°C) or T5 (-60°C ≤ T _a ≤ +80°C) certified to CENELEC standards. Weather Protection IP66/NEMA 4X investment cast in austenitic stainless steel.	4

Models

TABLE 2



S21/2

For applications up to 100 bar (1500 psi).
Maximum working pressure 155 bar (2250 psi).

S24

For applications up to 700 bar (10,000 psi). Maximum working pressure 1000 bar (15,000 psi).



Applies only to models S21/S24



	Code
Fixed Switching Differential SPDT & DPDT options available. See Table 6.	S21
Adjustable Switching Differential (Limited Span) Achieved by special microswitch with built in adjuster, SPDT only. See Table 6.	S22
Fixed Switching Differential SPDT & DPDT options available. See Tables 6.	S24

Electrical Entry

TABLE 3



Industrial Series		Enclosure							
Code	Description	W	5	A	4	H	R	T	U
0	M20 x 1.5 ISO Thread	a	a	*	*	*	*		
1	22mm (0.86 ins) Dia clearance hole for 20mm / ¾ inch O/Dia Conduit	*	*						
2	½ NPT Internal Thread	a	a	a	a	*	*		
3	¾ NPT Internal Thread	a	a	a	a	*	*	*	*
4	½ NPT Internal Dual Entry	a	a	a	a	*	*		
5	M20 x 1.5 Dual Entry	a	a	a	a	*	*		
6	¾ NPT Internal Dual Entry	a	a	a	a	*	*	*	*
7	22mm (0.86 ins) Dia clearance hole for 20mm / ¾ inch O/Dia Conduit Dual Entry	*	*						

a = Available with adaptor only
* = Available as Integral Connection
■ = Not available

For codes 3 & 6 on T & U only – see Approvals and Table 1

Material of Wetted parts

TABLE 4



WELDED CONSTRUCTION

Code S and T.

For reduced risk against leakage under extreme or unusual conditions the diaphragm may be welded directly to the process connection, eliminating the O-ring.

Welded construction not available on ranges CC to CE (CW to CK). (See Table 5)



Applies to all materials



	Code
316 stainless steel diaphragm, process connection and Viton O-ring seal.	A
316 stainless steel diaphragm, process connection and nitrile (Buna-N) O-ring seal.	G
Nickel alloy (Monel) diaphragm, 316 stainless steel process connection and Viton O-ring seal for applications as laid down in NACE MR 01-75.	K
Nickel alloy (Monel) diaphragm, 316 stainless steel process connection and Nitrile O-ring seal.	P
316 Stainless steel diaphragm and process connection. All welded construction.	S
Nickel alloy (Monel) welded diaphragm and process connection. (Suitable for NACE MR 01-75)	T

Setting Ranges & Performance Data

TABLE 5

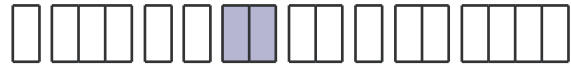

When ordering, please state units required. Range and set point will be in units of preference.

P_{max} = maximum working pressure



Applies only to all ranges







P_{max}		Model	Range					Code	
bar	psi		bar	mbar	Code	psi	In.Hg		In.H ₂ O
15	217	S21		12 to 250	CC			5 to 100	CW
				-120 to +120	CD			-50 to +50	CH
				100 to 600	CE			1.5 to 8.5	CK
				-1000 to 0	A0			-30 to 0	AB
			-1 to +1.5		G3	-14.5 to 20		GK	
27	400	S21/2	0.25 to 1.6		DB	4 to 25			DK
			0.4 to 2.5		DC	6 to 40			DP
			1 to 6		DE	16 to 100			DZ
70	1000	S21/2	1.6 to 10		EA	25 to 160			EH
			2.5 to 16		EB	40 to 250			EM
110	1600	S21/2	4 to 25		EC	60 to 400			ER
			10 to 40		ED	160 to 600			EW
			15 to 75		EF	250 to 1000			EE
155	2250	S21/2	10 to 100		FA	160 to 1500		F6	

P_{max}		Model	Range			
bar	psi		bar	Code	psi	Code
-1 to 600	-30 to 8700	S24	0.4 to 2.5	DC	6 to 40	DP
			1 to 6	DE	16 to 100	DZ
			1.6 to 10	EA	25 to 160	EH
			2.5 to 16	EB	40 to 250	EM
			4 to 25	EC	60 to 400	ER
			10 to 40	ED	160 to 600	EW
			15 to 75	EF	250 to 1000	EE
			10 to 100	FA	160 to 1500	F6
			7 to 160	U7	100 to 2300	UK
			25 to 250	V7	350 to 3500	VC
1000	15000	50 to 400	W7	800 to 6000	W9	
		100 to 700	Y4	1600 to 10000	YF	

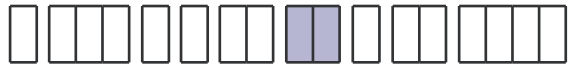
Switch Options

TABLE 6



Model S21 / 4										
UL/CSA Rating (RESISTIVE) §SEE NOTE	IEC 947-5-1/EN 60947-5-1 RATING								Contact	Code
	Designation & Utilization Category	Rated operational current / e (A) at rated operational voltage Ue	U _i	U _{imp}	VA Rating					
						Make	Break			
5 Amps @ 110/250V AC Light Duty for AC only	AC14 D300 DC13 R300	0.6/0.3A @ 120/240V AC	250V	0.8kV	AC DC	432 28	72 28	SPDT	00	
		0.22/0.1A @ 125/250V DC						DPDT	01	
5 Amps @ 110/250V AC & 2 Amps @ 30V DC General purpose precision	AC14 D300 DC13 R300	0.6/0.3A @ 120/240V AC	250V	0.8kV	AC DC	432 28	72 28	SPDT	02	
		0.22/0.1A @ 125/250V DC						DPDT	03	
1 Amp @ 125V AC & §100mA @ 30V DC Gold alloy contacts for low voltage switching	1 A @ 125 VAC RESISTIVE (IEC 1058-1/EN 61058-1)							SPDT	04	
								DPDT	05	
§ 5 Amps @ 110/250V AC & 5 Amps @ 30V DC Environmentally sealed	AC14 D300 DC13 R300	0.6/0.3A @ 120/240V AC	250V	0.5kV	AC DC	432 28	72 28	SPDT*	08	
		0.22/0.1A @ 125/250V DC						DPDT*	09	
15 Amp @ 125/250/ 480 V AC General purpose precision	AC14 D300	0.6/0.3A @ 120/240V AC	250V	0.8kV	AC	432	72	SPDT	10	
								DPDT	11	
§ 1 Amp @ 30V AC & 30V DC Environmentally sealed with gold contacts	AC14 E150	0.3A @ 120V AC	125V	0.5kV	AC	216	36	SPDT*	0G	
								DPDT*	0H	
5 Amps @ 250V AC & 2 Amps @ 30V DC Hermetically sealed. Gold plated silver contacts.	AC14 D300 DC13 R300	0.6/0.3A @ 120/240V AC	250V	0.5kV	AC DC	432 28	72 28	SPDT	H2	
		0.22/0.1A @ 125/250V DC						DPDT		H3†, H6‡
† 2 Single pole, double throw, simultaneous falling under pressure ‡ 2 Single pole, double throw, simultaneous rising under pressure										
Model S22										
5 Amps @ 110/250V AC Adjustable for AC only	AC14 D300	0.6/0.3A @ 120/240V AC	250V	0.8kV	AC	432	72	SPDT	0C	
5 Amps @ 110/250V AC & 2 Amps @ 30V DC Adjustable	AC14 D300 DC13 R300	0.6/0.3A @ 120/240V AC 0.22/0.1A @ 125/250V DC	250V	0.8kV	AC DC	432 28	72 28	SPDT	0D	
<p>NOTE 1: Enclosure Codes T and U. Microswitch Codes 02 and 03. UL/CSA rating as follows:- 110/250V AC 5A 125/250V DC 0.5/0.25A</p> <p>Enclosure Codes H and R. Microswitch Codes 02 and 03. UL/CSA rating as follows:- 110/250V AC 5A 250V/125/30V DC 0.25/0.5/2A</p> <p>NOTE 2: Using Codes H2, H3, H6 increases the Gas Class to: Class 1, Groups A, B, C and D, Div 2., for Enclosures T and U.</p> <p>  00, 01, 02, 03, 04 & 05 microswitches</p> <p> H2, H3† & H6‡ microswitches UL recognised component for use in Hazardous areas Class 1, Div 2, Groups A, B, C and D. Class II Groups F And G. When used in enclosure T and U.</p> <p> H2, H3† & H6‡ microswitches CSA accepted component for use in hazardous. areas Class 1, Div 2, Groups A, B, C and D. When used in enclosures T and U.</p> <p>The electrical rating is dependent on the microswitch fitted to the instrument. The electrical ratings defined by each approval that the microswitch complies with and is shown on the product nameplate, ie UL/CSA, or IEC. It should be noted that the instrument must be used within the electrical rating specified from the approval you require. This table lists the actual IEC ratings against the Designation & Utilization Category marked on the nameplates. In the absence of any verification by UL/CSA the microswitch § manufacturer's rating is stated in italics and bold. If in doubt seek guidance from the factory.</p> <p>NOTE: For low energy circuits e.g. 30V and up to 100mA, we recommend using gold alloy contact switches. U_i = rated insulation voltage U_{imp} = rated impulse withstand voltage across contacts.</p>										

Process Connection



Applies to all connections in this table

TABLE 7



	Code
Rc 1/4 (1/4 BSP tr INT) to (ISO 7/1)	A
1/4 – 18NPT INT	F
1/2 – 14NPT INT	H
1/2 – 14NPT EXT	J

Options & Treatments



Applies to all options and treatments in this table

TABLE 8



	Code
Tropicalisation High humidity environment	01
Marine and Offshore Saline atmosphere or salt spray	02
Ammonia Process (wetted) parts and construction suitable for atmospheric ammonia	03
Oxygen Service 2: Process (wetted) parts are cleaned for oxygen	04
Oxygen Service 3: Process and non-process parts are cleaned for use with oxygen	05
Stainless Steel Pipe Mounting Bracket Permits local 2" pipe work to be utilised for mounting the instrument	10
Category IV Safety Accessory as defined in the Pressure Equipment Directive 97/23/EC	60
Tagging - Variety of tagging methods are available	APPLY FOR DETAILS
Applies when – no option is required and selection is made from special engineering	00

Special Engineering



Refer to engineering

TABLE 9



	Code
Please consult Delta sales engineering for special requirements	TBA

Performance Data

Due to manufacturing tolerances the figures quoted in these tables are for guidance only.

Should the differential be critical for specific applications, our engineers should be consulted prior to ordering.

TABLES 10A, 10B, 10C, 10D.
MODELS S21, S24
FIXED SWITCHING DIFFERENTIAL

TABLE 10

MODEL S21			PSI UNITS										TABLE 10A
Range code	Range H ₂ O / in Hg / psi	P _{max} psi	SWITCHING OPTIONS SWITCHING DIFFERENTIAL IN H ₂ O / in Hg / psi										
			00	01	02	03	04	05	08/0G	09/0H	H2	H3/H6	
CW	5 to 100	217	2	3.1	3.5	5.5	2	2.4	3.1	6	11.7	11.7	
CH	-50 to +50	217	3.1	5.5	3.1	9	3.1	3.1	5.5	7	8	8	
CK	1.5 to 8.5	217	3.1	5.5	6	9	3.1	4.7	5.5	7	18	18	
AB	-30 to 0	217	0.6	0.8	1.3	1.7	0.5	0.5	0.8	1	3	3	
GK	14.5 to +20	218	0.3	0.6	0.7	1.5	0.3	0.4	0.5	0.7	2.2	2.2	
DK	4 to 25	400	0.4	0.7	1	1.5	1	1.5	2.6	3.5	1.2	2.3	
DP	6 to 40	400	0.4	0.7	1	1.5	1	1.5	2.6	3.5	1.2	2.3	
DZ	16 to 100	400	0.6	0.9	1.7	2	1.5	2.2	3.5	1.6	2.9	5.8	
EH	25 to 160	1000	1.5	2.2	3.6	6.5	2.2	3.3	11.6	14.5	6	11.6	
EM	40 to 250	1000	2.2	4	5.1	9.9	3.6	5.8	13.1	17.4	7.5	14.5	
ER	60 to 400	1600	4.4	6.5	15.2	19.6	7.3	10.2	26	35	26	52	
EW	160 to 600	1600	7.3	11.6	20	26	11.6	17.4	44	46	31	61	
EE	250 to 1000	1600	9.4	14.5	25	33	14.5	22	44	58	51	102	
F6	160 to 1500	2250	14.5	22	51	65	29	44	87	116	73	145	

MODEL S21			SI UNITS										TABLE 10B
Range code	Range mbar/bar	P _{max} bar	SWITCHING OPTIONS SWITCHING DIFFERENTIAL IN mbar										
			00	01	02	03	04	05	08/0G	09/0H	H2	H3/H6	
CC	12 to 250	15	5	8	6	8	5	6	8	15	30	30	
CD	-120 to +120	15	8	14	8	23	8	8	14	18	20	20	
CE	100 to 600	15	8	14	15	23	8	12	14	18	45	45	
A0	-1000 to 0	15	21	27	45	60	18	18	30	36	105	105	
G3	-1 to +1.5	15	21	40	48	100	24	30	36	45	150	150	
DB	0.25 to 1.6	27	30	45	70	100	70	100	180	240	80	160	
DC	0.4 to 2.5	27	30	45	70	100	70	100	180	240	80	160	
DE	1 to 6	27	40	60	120	140	100	150	240	320	200	400	
EA	1.6 to 10	70	100	150	250	450	150	230	800	1000	400	800	
EB	2.5 to 16	70	150	275	350	680	250	400	900	1200	500	1000	
EC	4 to 25	110	300	450	1050	1350	500	700	1800	2400	1800	3600	
ED	10 to 40	110	500	800	1400	1800	800	1200	3000	3200	2100	4200	
EF	15 to 75	110	650	1000	1750	2250	1000	1500	3000	4000	3500	7000	
FA	10 to 100	155	1000	1500	3500	4500	2000	3000	6000	8000	5000	10000	

MODEL S24			PSI UNITS										TABLE 10C
Range code	Range psi	P _{max} psi	SWITCHING OPTIONS SWITCHING DIFFERENTIAL IN psi										
			00	01	02	03	04	05	08/0G	09/0H	H2	H3/H6	
DP	6 to 40	8700	3.2	4.8	5.8	5.8	4.4	4.4	6.5	7.4	6	11.6	
DZ	16 to 100	8700	3.5	5.8	8.7	11.6	7.3	10.2	8.7	9.4	12	23	
EH	25 to 160	8700	5.5	10.2	11.6	17.4	8.7	13	8.7	11	18	35	
EM	40 to 250	8700	6.7	11.5	11.6	17.4	8.7	13	11.6	17.4	18	35	
ER	60 to 400	8700	12.5	20	17.4	23	11.6	17.4	20	22	34	67	
EW	160 to 600	8700	14.5	23	29	44	22	36	29	44	51	102	
EE	250 to 1000	8700	22	28	36	73	22	58	44	58	58	116	
F6	160 to 1500	8700	29	36	65	87	51	73	58	73	73	145	
UK	100 to 2300	15000	49	80	99	145	58	77	73	90	150	290	
VC	350 to 3500	15000	81	162	145	244	122	203	725	870	370	725	
W9	800 to 6000	15000	128	255	255	574	192	319	1160	1160	600	1160	
YF	1600 to 10000	15000	218	435	290	653	326	486	1450	1450	750	1450	

MODEL S24			SI UNITS										TABLE 10D
Range code	Range bar	P _{max} bar	SWITCHING OPTIONS SWITCHING DIFFERENTIAL IN mbar										
			00	01	02	03	04	05	08/0G	09/0H	H2	H3/H6	
DC	0.4 to 2.5	600	220	330	400	400	300	300	450	510	400	800	
DE	1 to 6	600	240	400	600	800	500	700	600	650	800	1600	
EA	1.6 to 10	600	380	700	800	1200	600	900	600	750	1200	2400	
EB	2.5 to 16	600	480	790	800	1200	600	900	800	1200	1200	2400	
EC	4 to 25	600	860	1400	1200	1600	800	1200	1350	1500	2300	4600	
ED	10 to 40	600	1000	1600	2000	3000	1500	2500	2000	3000	3500	7000	
EF	15 to 75	600	1500	1900	2500	5000	1500	4000	3000	4000	4000	8000	
FA	10 to 100	600	2000	2500	4500	6000	3500	5000	4000	5000	5000	10000	
U7	7 to 160	1000	3400	5500	6800	10000	4000	5300	5000	6200	10000	20000	
V7	25 to 250	1000	5600	11200	10000	16800	8400	14000	50000	60000	35000	50000	
W7	50 to 400	1000	8800	17600	17600	39600	13200	22000	80000	80000	40000	80000	
Y4	100 to 700	1000	15000	30000	20000	45000	22500	33500	100000	100000	50000	100000	

Performance Data

TABLE 10 TABLES 10E, 10 F. MODEL S22 ADJUSTABLE SWITCHING DIFFERENTIAL

MODEL S22		PSI UNITS			TABLE 10E			
Range code	Range psi	Pmax psi	SWITCHING OPTIONS SWITCHING DIFFERENTIAL IN psi					
			MIN	0C	MAX	MIN	0D	MAX
DK	4 to 25	400	0.2	1.1	1	2.9		
DP	6 to 40	400	0.3	1.2	1.3	3		
DZ	16 to 100	400	0.5	2.8	2.5	7.3		
EH	25 to 160	1000	1.9	6.2	6.4	16		
EM	40 to 250	1000	3.2	9.1	9.6	23		
ER	60 to 400	1600	9.6	35	41	88		
EW	160 to 600	1600	13	61	57	125		
EE	250 to 1000	1600	16	62	80	160		
F6	160 to 1500	2250	25	83	96	212		

MODEL S22		SI UNITS			TABLE 10F			
Range code	Range bar	Pmax bar	SWITCHING OPTIONS SWITCHING DIFFERENTIAL IN mbar					
			MIN	0C	MAX	MIN	0D	MAX
DB	0.25 to 1.6	27	11	78	66	200		
DC	0.4 to 2.5	27	22	82	88	210		
DE	1 to 6	27	33	190	170	500		
EA	1.6 to 10	70	132	430	440	1100		
EB	2.5 to 16	70	220	630	660	1600		
EC	4 to 25	110	660	2400	2800	6100		
ED	10 to 40	110	880	3300	3900	8600		
EF	15 to 75	110	1100	4300	5500	11000		
FA	10 to 100	155	1700	5700	6600	14600		

Technical Specifications

ACCURACY

Set point repeatability $\pm 1\%$ of span at 20°C ambient.

AMBIENT TEMPERATURE RANGE

All models are suitable for operating within a range of -25 to +60°C (-13 to +140°F). Enclosures A, H, R, T, U, on Models S21 ad S24 with ranges CC to FA may be used intermittently down to -60 and up to +80°C (-76 to +176°F). For continuous use below -25°C (-13°F) we recommend using only enclosures H, R, T, U and A with special gaskets and limited switching.

MAXIMUM PROCESS TEMPERATURE

Subject to appropriate installation practice, the component parts withstand up to +60°C (+140°F). For process temperatures up to +120°C (+248°F), order **WETTED PARTS** Code A (Table 4) and for higher temperatures, refer to **SPECIAL ENGINEERING**.

ELECTRICAL CONNECTIONS

Terminal Block

Cable entry is to a non-pinching terminal block made of a non-hygroscopic thermosetting plastic, suitable for cables up to 2.5mm²/14AWG.

Earthing/Grounding

An earthing facility is provided inside all weatherproof enclosures, adjacent to the entry. External earthing is standard on flameproof versions. Safety note – see Table 3.

Dielectric Strength

The electrical assembly is capable of withstanding *2kV between live parts and earth/ground and 500V between open contacts.

*1.2kV for microswitch Codes H2, H3 and H6. Refer to Table 6.

Electrical Entry

Standard options are listed in Table 3. Other threads can be accommodated by adaptors. Dual entry available, see Table 3.

OPTIONAL EXTRAS

Chemical Seals

Chemical seals of our own or proprietary manufacture can be fitted when required.

Weights

UNIT WEIGHTS (Approx)			
	RANGE AND MODEL		
	S21/2		S24
	CC	ALL OTHER RANGES	ALL RANGES
Enclosures	CD		
	CE		
H & T	3.5kg / 7.7lb	2.7kg / 5.9lb	2.8kg / 6.1lb
U & R	6.6kg / 14.5lb	5.8kg / 12.8lb	5.9kg / 13lb
W	3.1kg / 6.8lb	2.6kg / 5.7lb	2.9kg / 6.4lb
A	4.2kg / 9.2lb	3.8kg / 8.4lb	4kg / 8.8lb

Operation / Installation

Mounting Position / Location / Installation

Vertical as shown, taking care to avoid siting in locations or vibration. For further advice contact our engineers.

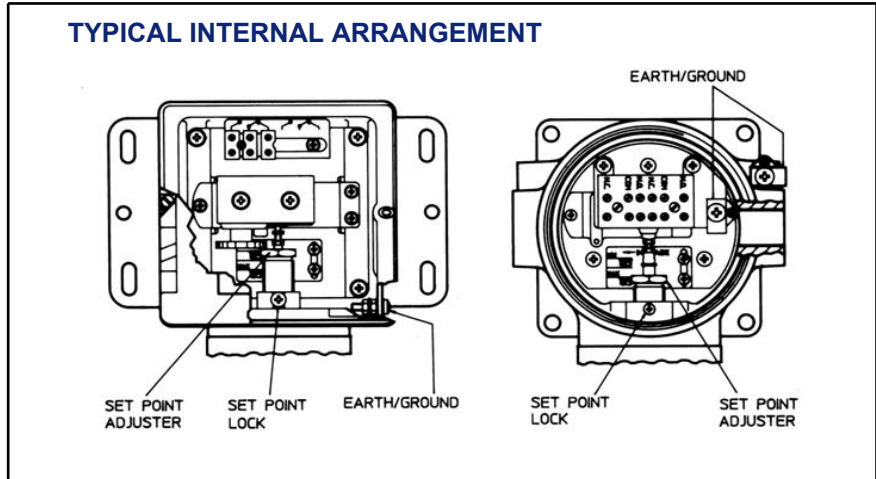

Approvals

INTRINSIC SAFETY

Because of the low voltages and currents of intrinsically safe circuits, we recommend using gold contacts. Refer to Table 6.

CENELEC/BASEEFA

Certified to CENELEC EN50 014 and EN50 018.

For use in Zone 1 hazardous areas EEx d IIC T6 (-60° to + 65°C)
T5 (-60° to + 80°C)



II 2GD

Enclosure Codes H and R and all models (see Table 1)

Certificate number BASEEFA 01ATEX02113X

UNDERWRITER LABORATORIES INC.

NOWT.

Float – and Pressure – Operated Motor Controller. For use in Hazardous locations



E134197 (N)

Enclosure codes T & U Class 1, Groups C & D Class II, Groups E, F, G

CANADIAN STANDARDS ASSOCIATION

Switches – Automatic – Pressure Type – for hazardous locations

Enclosure codes T & U.

Class 1, Groups C & D Class II, Groups E, F, G.

LR94185-2



CENELEC / ATEX CAT 1 / 2 (2/3 S24)

EExd IIC II 1 / 2 GD

BASEEFA01ATEX2113X VARIATION 8 & 9

CENELEC / ATEX CAT 1 (5/4)

EEx ia II 1 GD

BASEEFA05ATEX0111

SAFETY INTEGRITY LEVEL (SIL)

IEC 61508 Part 1 and 2

Systematic integrity and random integrity SIL2 Capable

Certificate number DC060816 C001

Dimensions

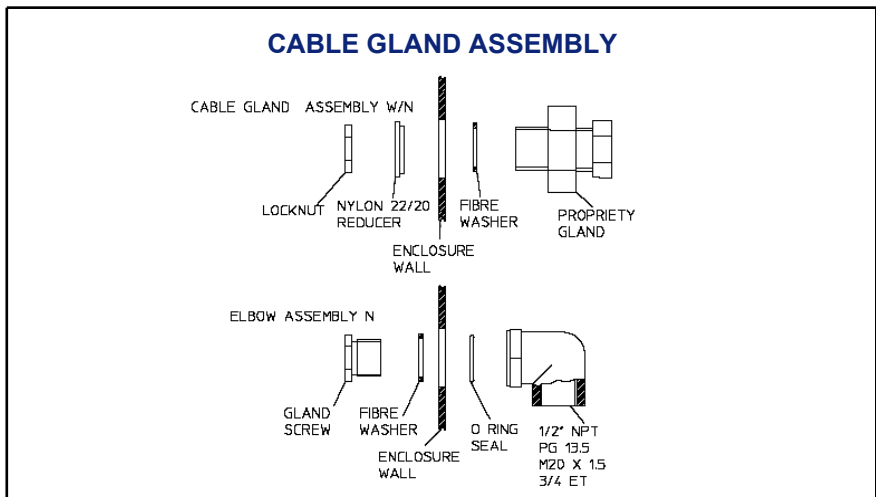

Dimensions

'B', 'H', 'R', 'T', 'U' ENCLOSURE

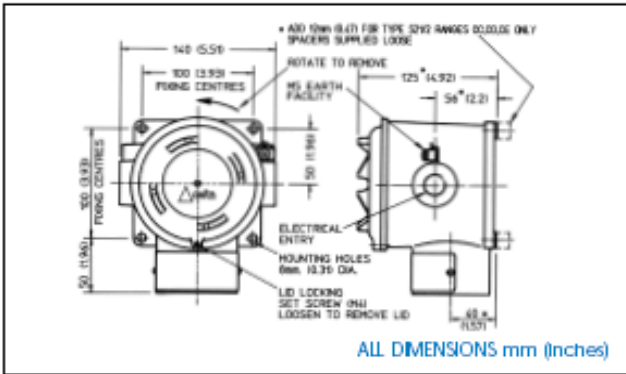

'W' ENCLOSURE

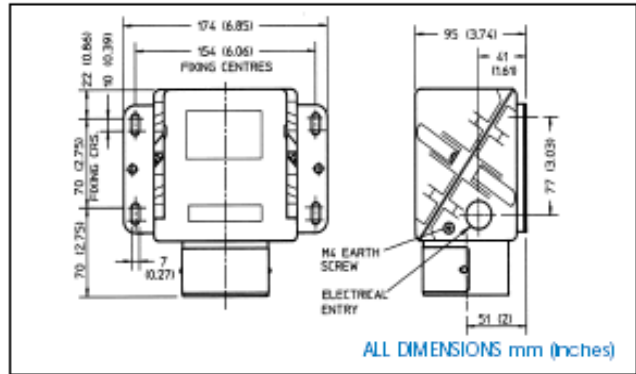

'A' ENCLOSURE

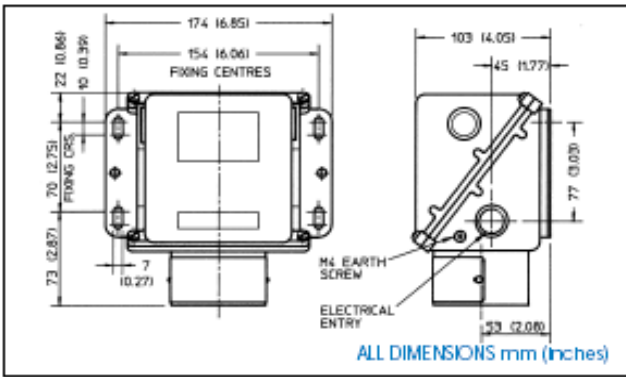

MODEL S21/2 ALL RANGES CC, CD, CE

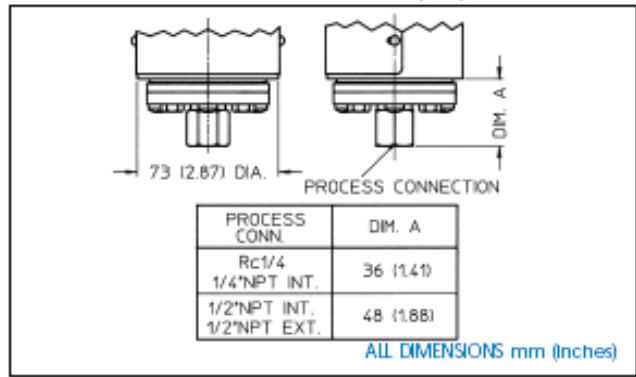

MODEL S21/2 RANGES CC, CD, CE

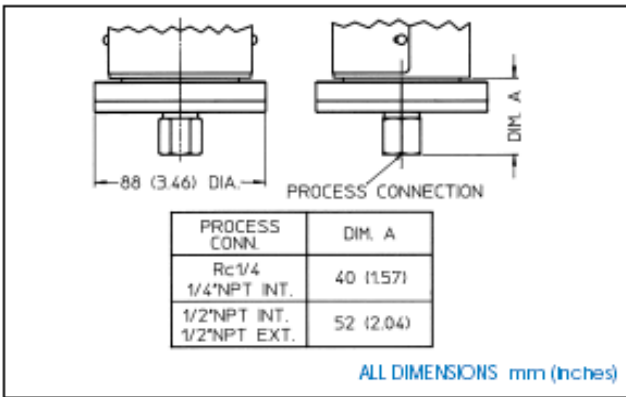

MODEL S24 ALL RANGES

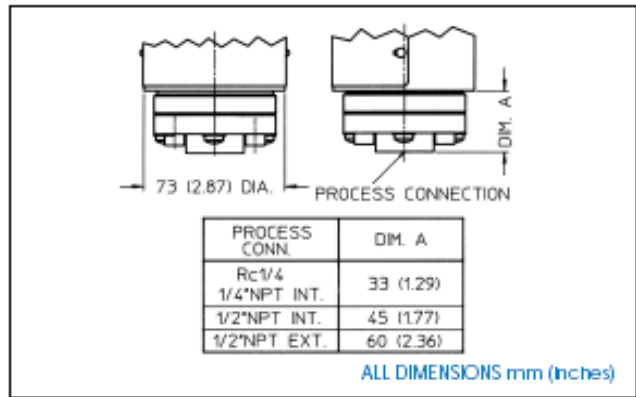

In the interest of development and improvement Delta Controls Ltd, reserves the right to amend, without notice, details contained in this publication. No legal liability will be accepted by Delta Controls Ltd for any errors, omissions or amendments.



Delta Controls Limited

Island Farm Avenue, West Molesey, Surrey KT8 2UZ, UK.
 T+44 (0)20 8939 3500 F+44 (0)20 8783 1163 E sales@delta-controls.com W www.delta-controls.com