

## Compact Diaphragm Operated Pressure Difference Switches **GR** Series

- Compact and rugged design.
- Hermetically sealed snap switch UL and CSA listed.
- ATEX - Flameproof CENELEC EEx d IIC option.
- ATEX – Intrinsically Safe ATEX Ex ia IIC option.
- Weatherproof IP66/NEMA 4.
- Stainless steel body option NEMA 4X rating.
- Maximum Working (Static or line) Pressure up to 250 Bar / 3500 psi.
- Ranges available up to 10 bar / 160 psi.
- Variety of wetted parts including NACE MR 01-75 compatibility option.
- Optional weatherproof, ATEX EEx e, ATEX Ex ia or ATEX - Flameproof EEx d IIC terminal enclosures.
- Field adjustable.
- Accuracy 1%

### Performance **characteristics**

#### Enclosure options

- IP66 Protection Nema 4 (Standard)
- Option Nema 4X.

#### Wetted parts options

- 316 Stainless Steel (with PTFE & Viton or Nitrile O-ring seals)
- Sour Gas or Sour Crude applications (MR 01-75) – NACE.
- Nitrile with aluminium or cast iron flanges.

#### Standard Electrical ratings – Refer to Table 6

- 11 Amp silver contacts
- 5 Amp silver contacts
- 1 Amp gold contacts

#### Process connection

- Rc ¼ (BSP), ¼ NPT Internal, ½ NPT Internal, ½ NPT External.

#### Unit weight

- Between 2.7 kg – 8.4kg (6lb – 18.4lb) see end of datasheet for different instrument weights.

#### Accuracy

- Set point repeatability ± 1% of span at 20 °C / 68 °F ambient.

GR3/6  
ISSUE D



### Product **applications**

The GR series is suitable for a wide range of applications in many industry sectors:

- Oil & Gas
- Chemical
- Petrochemical
- OEM

The choice of models available ensures that the GR Series is suitable for use in:

- Corrosive atmospheres
- Resistant to chemical attack

### How can we **help you?**

Delta Controls' range of reliable pressure and temperature measurement instruments can be customised to meet individual requirements. For technical advice or to discuss your application please contact us on +44 (0) 20 8939 3500

## Enclosure





TABLE 1



### FINISH

Enclosures W and H are clear anodised aluminium; Epoxy paint is optional see Code 50 in Table 8. A and R are natural finish stainless steel.

All are suitable for use in hazardous areas as defined by NEC Article 500, Class 1 Groups A, B, C, D Class II Groups E, F, G Division 1 and 2. See Table 3 Code A.

WEATHERPROOF ENCLOSURES	Code
<b>Aluminium General Purpose Weatherproof</b> For outdoor industrial use IP66/NEMA 4.	W
<b>Stainless Steel Weatherproof</b> For outdoor aggressive atmospheres e.g. marine NEMA type 4X/IP66	A
FLAMEPROOF ENCLOSURES	
<b>Aluminium Weatherproof/Explosionproof IP66/NEMA 4, 7, 9</b> With CENELEC approval EEx d IIC. II 2 G for Zone 1  See approvals.	H
<b>Stainless Steel Weatherproof/Explosionproof IP66/NEMA 4X, 7, 9</b> For use in aggressive atmospheres e.g. marine. With CENELEC approval EEx d IIC. II 2 G for Zone 1  See approvals.	R
INTRINSICALLY SAFE ENCLOSURES	
<b>Stainless Steel Weatherproof/Explosionproof IP66/NEMA 4</b> With ATEX approval Ex ia IIC. II 1 G/D for Zone 0  II 1GD See approvals.	4
<b>Aluminium Weatherproof/Explosionproof IP66/NEMA 4X</b> For use in aggressive atmospheres e.g. marine. With ATEX approval Ex ia IIC. II 1 G/D for Zone 0  II 1GD See approvals.	5

## Models

TABLE 2



<b>Fixed Switching Differential</b> Max working pressure 1bar/14.5psi. Or 110bar/1600psi. (See Tables 5A + 5B.)	GR3
<b>Fixed Switching Differential</b> Max working pressure 250bar /3500psi. (See Tables 5A + 5B.)	GR6

## Electrical Entry

**TABLE 3**

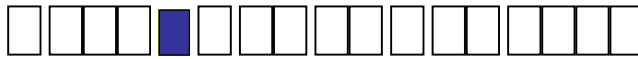

See **TECHNICAL DATA** and **DIMENSIONS** fig 1 to 5.

**NOTE 1:**





Other lengths available – please contact sales for engineering codes

**NOTE 2 :**

Weatherproof terminal enclosure Code C can only be combined with Table 1 Enclosure Codes W and A.

**NOTE 3 :**

Intrinsically Safe terminal enclosure Code V and W can only be combined with Table 1 Enclosure Codes 4 and 5.

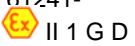
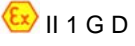
<p><b>Factory Sealed Flying Lead.</b> See fig. 1,2, 3 &amp; 4. Class I, Groups A, B, C, D; Class II Groups E,F,G. 0.45m/18 in. long flying lead (other lengths available) with 1/2-14 NPT external conduit thread.</p>	 	A
<p><b>Integral Weatherproof Terminal Enclosure.</b> See fig.5 Glass filled polyester with weather protection to IP66/NEMA 4. Conduit entry tapped M20 x 1.5. Ambient temperature -20 to +40°C</p>		C
<p><b>Integral 'Increased Safety' Terminal Enclosure.</b> See fig.5 EEx e IIC T6 (-20 to +40°C) Glass filled polyester certified to CENELEC EN50 014/EN50 019, with weather protection not less than IP66/NEMA 4. Conduit entry tapped M20 x 1.5.</p>		D
<p><b>Integral 'Increased Safety' Terminal Enclosure.</b> See fig.5 EEx e IIC T6 (-20 to +40°C) Glass filled polyester certified to CENELEC EN50 014/EN50 019, with weather protection not less than IP66/NEMA 4. Conduit entry tapped M20 x 1.5.</p>		J
<p><b>Explosionproof Terminal Enclosure.</b> See fig.5 CENELEC EExd IIC T6(-20 to +40°C) Die cast aluminium alloy. Conduit entry tapped ½ -14 NPT. Weather protection not less than IP65/NEMA 4</p>		K
<p><b>Intrinsically Safe Terminal Enclosure-With Screw Terminals</b> See fig 2. Ex ia IIC T6 (-20 to +40°C) Glass filled polyester certified to EN60079:2004, EN50020:2002, EN60079-26:2004, IEC 61241-0:2004 and EN61241-11:2005, with weather protection not less than IP66/ NEMA 4.</p>		V
<p><b>Intrinsically Safe Terminal Enclosure-With DIN Rail Mounted Terminals</b> See fig 2. Ex ia IIC T6 (-20 to +40°C) Glass filled polyester certified to EN60079:2004, EN50020:2002, EN60079-26:2004, IEC 61241-0:2004 and EN61241-11:2005, with weather protection not less than IP66/ NEMA 4.</p>		W

## Material of Wetted Parts

**TABLE 4**

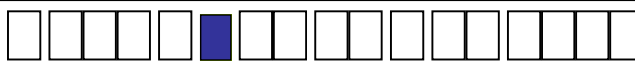

RANGES	See fig. 2 to 4 for dimensions	Code
BD-EA	316 Stainless steel diaphragm. All other wetted parts fully austenitic 300 series stainless steel. PTFE and Nitrile seals.	I
	316 Stainless steel diaphragm. All other wetted parts fully austenitic 300 series stainless steel. PTFE and Viton Seals.	R
	For wetted parts required to conform with Sour Gas or Sour Crude applications as laid down in NACE standard MR-01-75.	L
BC	Nitrile diaphragm and seal with aluminium flanges <b>range BC only – enclosure H, W.</b>	D
	Nitrile diaphragm and seal with cast iron flanges <b>range BC only – enclosure R, A.</b>	E

**Setting Ranges & Performance Data**

TABLE 5

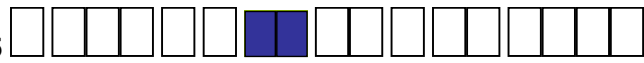

**Table 5A: SI Units**

MODEL	RANGE CODE		$P_{max}$	RANGE	SWITCHING DIFFERENTIAL – REFER TO TABLE 6 mbar					
	GR3	GR6			bar	mbar/bar	HS	HD / HR	HP	HQ / HT
GR3 / 6	BC	-	1	-12.5 to +12.5	1.5	3	2.5	3.5	1.5	3
	BD	0D	110 (GR3) 250 (GR6)	6 to 40	7.5	14	11	14	7.5	14
	CB	0B		25 to 160	16.5	20.5	19	23	16.5	20.5
	CE	0E		100 to 600	40	40	20	20	40	40
	DC	DC		0.4 to 2.5	150	200	180	280	150	200
	DD	DD		0.6 to 4	350	400	250	200	350	400
	EA	EA		1.6 to 10	800	1000	400	560	800	1000

**Table 5B: PSI Units**

MODEL	RANGE CODE		$P_{max}$	RANGE	SWITCHING DIFFERENTIAL – REFER TO TABLE 6 in.H <sub>2</sub> O / PSI					
	GR3	GR6			Psi	in.H <sub>2</sub> O/PSI	HS	HD / HR	HP	HQ / HT
GR3 / 6	BU	-	14.5	-5 to +5	0.6	1.2	1	1.4	0.6	1.2
	BY	0Y	1600(GR3) 3500(GR6)	2.5 to 16	3	5.6	4.4	5.6	3	5.6
	CS	IS		10 to 64	6.6	8.2	7.6	9.2	6.6	8.2
	CK	0K		1.5 to 8.5	0.6	0.6	0.3	0.3	0.6	0.6
	DP	DP		6 to 40	2.2	3	2.6	4	2.2	3
	DT	DT		10 to 60	5	6	3.6	2.9	5	6
	EH	EH		25 to 160	11.6	14.5	5.8	8	11.6	14.5

Due to manufacturing tolerances the figures quoted in these tables are for guidance only and are typical for weatherproof models. Flameproof models may be up to 2 times higher depending on the range. Should the differential be critical for specific applications, our engineers should be consulted prior to ordering.

## Switching Options

TABLE 6

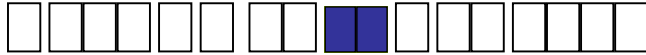

The switch contacts are hermetically sealed inside a stainless steel enclosure for protection against aggressive and corrosive atmospheres. UL & CSA listing applies to the explosionproof hermetically sealed switch which is suitable for use in hazardous areas as defined by NEC Article 500, Class I Groups A,B,C,D Class II Groups E,F,G Division 1 and 2.



UL/CSA Rating	IEC 947-5-1/EN 60947-5-1 Rating							Contact	Code
	Designation & Utilization Category	Rated operational current I <sub>e</sub> (A) at rated operational voltage U <sub>e</sub>	U <sub>i</sub>	U <sub>imp</sub>	VA Rating				
					Make	Break			
11 Amps @ 110/250V AC & 5/0.5 Amps @ 30/125V DC Silver contacts	AC14 D300	0.6/0.3A @ 120/240V AC	250V	800V	432	72	SPDT DPDT DPDT	HS HD † HR ‡	
	DC13 R300	0.22/0.1A @ 125/250V DC			28	28			
5 Amps @ 250V AC & 2 Amps @ 30V DC Silver contacts with gold flash	AC14 D300	0.6/0.3A @ 120/240V AC	250V	500V	432	72	SPDT DPDT DPDT	HP HQ † HT ‡	
	DC13 R300	0.22/0.1A @ 125/250V DC			28	28			
1 Amp @ 125V AC & 1 Amp @ 30V DC Gold Alloy contacts – see note	AC14 E150	0.3A @ 120VAC	125V	500V	216	36	SPDT DPDT DPDT	HV † HW ‡ HY ‡	

† ‡ Single pole, double throw, simultaneous falling under pressure  
‡ † Single pole, double throw, simultaneous rising under pressure.

NOTE: For low energy circuits e.g. 30V and up to 100mA, we recommend using gold alloy contact switches.  
NOTE: For Enclosure codes 4 and 5, HS, HD and HR switching codes are unsuitable. Use gold contact switches.

U<sub>i</sub> = rated insulation voltage      U<sub>imp</sub> = rated impulse withstand voltage across contacts.

## Process Connection

TABLE 7



Other thread specifications and sizes are available without using adaptors.

Adaptors are available for applications where their use is permitted. Apply for details.

	Code
Rc 1/4 (1/4 BSP tr INT) to (ISO 7/1)	A
1/4 – 18NPT INTERNAL	F
1/2 – 14NPT INTERNAL	H
1/2 – 14NPT EXTERNAL	J

## Options & Treatments

TABLE 8



	Code
<b>Tropicalisation</b> High humidity environment	01
<b>Marine and Offshore</b> Saline atmosphere or salt spray	02
<b>Ammonia</b> Process (wetted) parts and construction suitable for atmospheric ammonia.	03
<b>Oxygen Service</b> Process (wetted) parts are cleaned for oxygen and are oil free.	04
<b>Pipe Mounting Bracket</b> permits local 2" pipework to be utilised for mounting the instrument. Details on application.	10
<b>Tag</b> Stainless steel <b>fixed</b> to enclosure.	20
<b>Tag</b> Stainless steel <b>tied</b> to enclosure.	30
<b>No options or Treatments</b> Use this code when Special Engineering is required without options and treatments	00
<b>Epoxy Paint</b> for aluminium enclosures W, H in Table 1	50

## Special Engineering

TABLE 9



FEATURE	Code
Consult Delta Sales Engineering for special requirements	TBA

## Unit Weights

UNIT WEIGHTS (Approximate) Refer to table 1		
GR3 Code H/W Ranges BC/BU	2.7kg	(6lb)
GR3 Code H/W Ranges BD/CB/CE	4.5kg	(9.9lb)
GR3 Code H/W Ranges BY/CS/CK	4.5kg	(9.9lb)
GR3 Code H/W Ranges DC/DD/EA	3kg	(6.6lb)
GR3 Code H/W Ranges DP/DT/EH	3kg	(6.6lb)
GR3 Code R/A Ranges BD/CB/CE	5kg	(11lb)
GR3 Code R/A Ranges BY/CS/CK	5kg	(11lb)
GR3 Code R/A Ranges DC/DD/EA	3.5kg	(7.7lb)
GR3 Code R/A Ranges DP/DT/EH	3.5kg	(7.7lb)
GR6 Code H/W Ranges OD/OB/OE	6.8kg	(15lb)
GR6 Code H/W Ranges OY/IS/OK	6.8kg	(15lb)
GR6 Code H/W Ranges DC/DD/EA	5.3kg	(11.7lb)
GR6 Code H/W Ranges DP/DT/EH	5.3kg	(11.7lb)
GR6 Code R/A Ranges OD/OB/OE	7.3kg	(16 lb)
GR6 Code R/A Ranges OY/IS/OK	7.3kg	(16 lb)
GR6 Code R/A Ranges DC/DD/EA	5.8kg	(12.7lb)
GR6 Code R/A Ranges DP/DT/EH	5.8kg	(12.7lb)
For integral terminal enclosures codes in Table 3		
	C/D add 0.3kg / 0.66lb	
	J add 1.1kg / 2.4lb	
	K add 0.4kg / 0.88lb	

## Technical Specifications

### ACCURACY

Set point repeatability  $\pm$  1% of span at 20°C/68°F.

### AMBIENT TEMPERATURE RANGE

Certified Enclosures.  
Refer to Approvals and Tables 1 & 3 for limitations of ambient use.

### OPERATION

Suitable for operating within a range of ambient temperatures from -40° to +80°C (-40° to 176°F)

### MAXIMUM PROCESS TEMPERATURE

Subject to appropriate installation practice the component parts will withstand +60°C (+140°F). For process temperatures up to +120°C (+248°F) order **wetted parts** Code R (Table 4), and for higher temperatures refer to **SPECIAL ENGINEERING**.

### ELECTRICAL CONNECTIONS

#### Flying Lead

High duty PVC insulated 1.19mm<sup>2</sup>/18 AWG factory sealed flying leads. Rated insulation voltage UL/CSA 600V.

#### Earthing/Grounding

An earthing facility is provided. Flying lead versions have separate earth/ground conductor. Terminal enclosures have additional internal earthing/grounding facilities.

#### Dielectric Strength

The electrical assembly is capable of withstanding \*1.5kV between live parts and earth/ground and 500V between open contacts.

### OPTIONAL EXTRAS

#### Pollution degree (EN60947-5-1)

All switches rated IP66 are suitable for use in pollution degree 3. Ref IEC 947-5-1.

**Electrical Isolation** – These products are not suitable for electrical isolation. Always isolate circuit separately to carry out any electrical work.

#### Mounting Location

Avoid sitting in locations that transmit excessive shock or vibration. For further advice contact our engineers.

#### Chemical Seals

Chemical seals of our own or proprietary manufacture can be fitted when required.

#### Pipe Mounting Bracket & Tagging

See Table 8

## Approvals

### INTRINSIC SAFETY

Because of the low voltages and currents of intrinsically safe circuits, we recommend using gold contacts - Refer to Table 6

### CENELEC/BASEEFA

Certified to CENELEC EN50 014 and EN50 018.  
For use in Zone 1 hazardous areas EEx d IIC T6 (-40° to +60°C)  
T4 (-40° to +85°C)



II 2 G

Enclosure Codes H and R and all models (see Table 1)

Certificate number BASOATEX0214X

### CENELEC/BASEEFA

Certified to ATEX EN60079:2004, EN50020:2002, EN60079-26:2004  
61241-0:2004 and EN61241-11:2005.



II 1 G D

For use in Zone 0 hazardous areas Ex ia IIC T6 (-40° to +60°C)  
T4 (-40° to +85°C)  
Ex iaD 20 T85 (-40° to +60°C)  
T135 (-40° to +85°C)

Enclosure Codes 4 and 5 and all models (see Table 1)

Certificate number BASEEFA06ATEX0091X

### UNDERWRITER LABORATORIES INC.

Snap switches for use in Hazardous Locations.  
Class 1, Groups A, B, C, D Class II, Groups E, F, G Division 1 and 2  
E105842



### CANADIAN STANDARDS ASSOCIATION

Snap switches for use in Hazardous Locations.  
Class 1, Groups A, B, C, D Class II, Groups E, F, G Division 1 and 2  
LR67110-5



## Dimensions

Figure 1

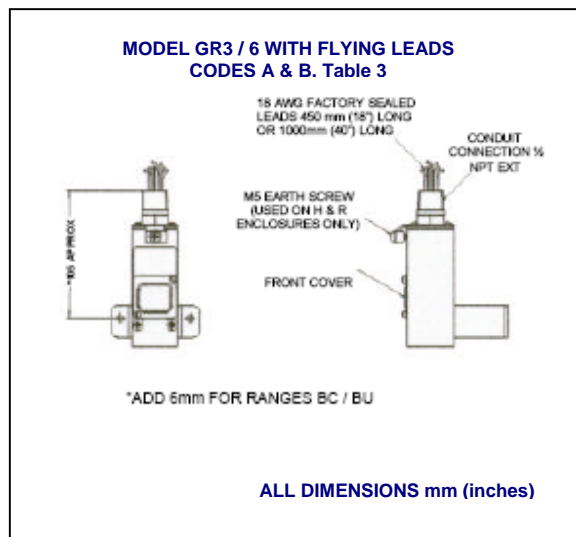

Figure 2

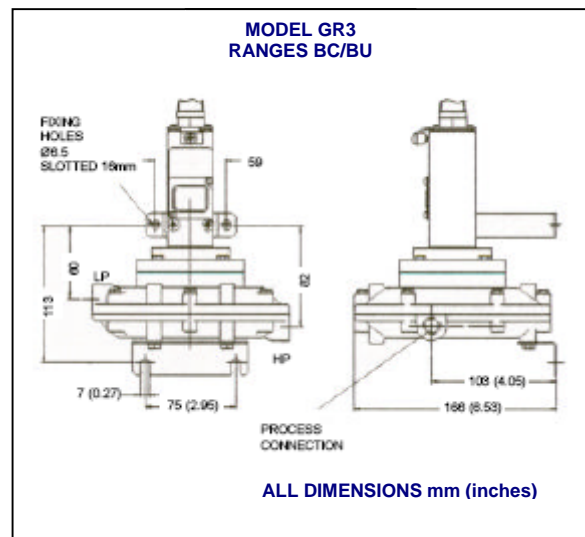

Figure 3

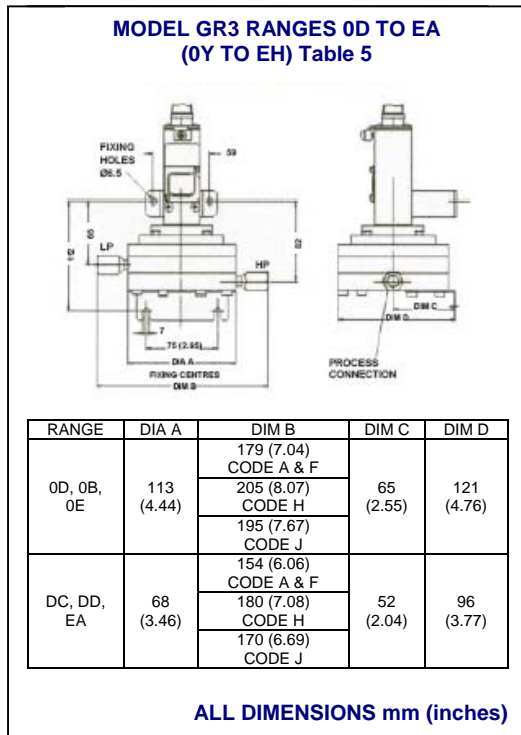

Figure 4

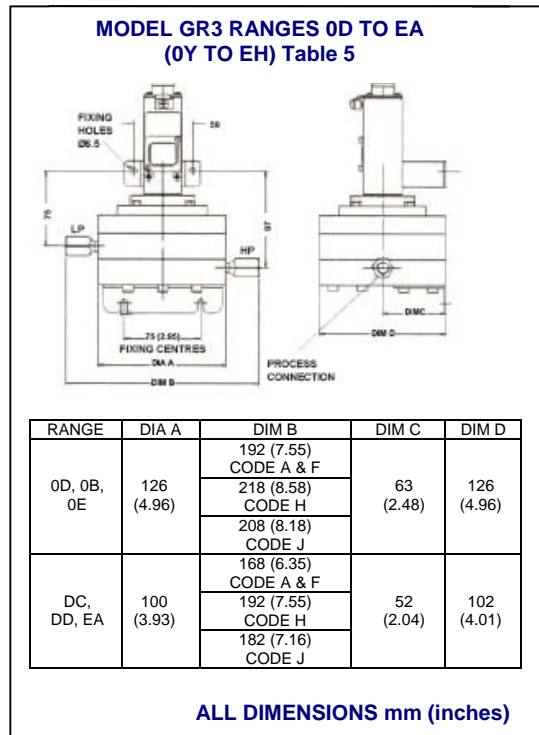
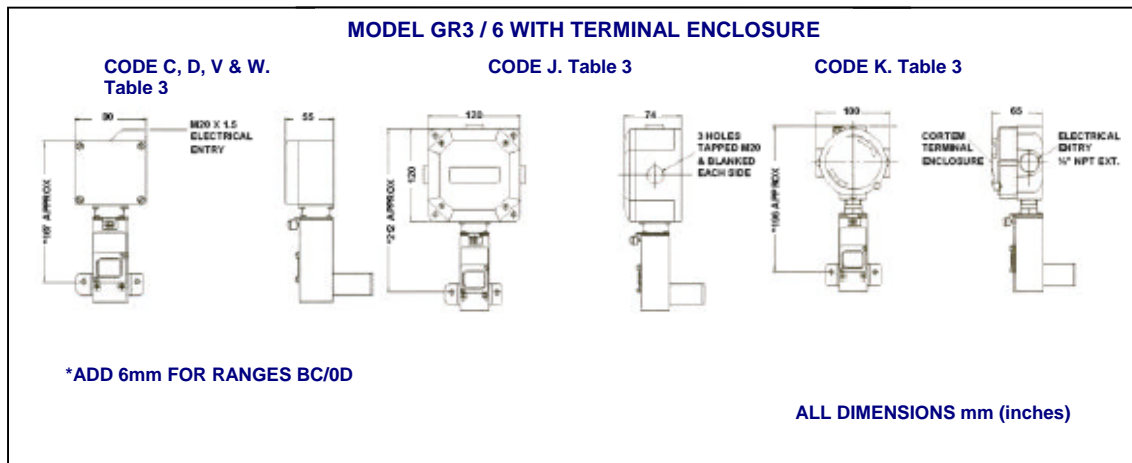

Figure 5



In the interest of development and improvement Delta Controls Ltd, reserve the right to amend, without notice, details contained in this publication.  
 Delta Controls Ltd will accept no legal liability for any errors, omissions or amendments.  
 We retain the right to supply Hastelloy Sensors as an alternative. If you require Stainless Steel please confirm with sales department



Delta Controls Ltd

Island Farm Avenue, West Molesey, Surrey, KT8 2UZ, United Kingdom

T+44 (0) 208 939 3500 F+44 (0) 783 1163 [E sales@delta-controls.com](mailto:sales@delta-controls.com) [W www.delta-controls.com](http://www.delta-controls.com)

