

Performance Vapour Pressure and Gas Filled Temperature Switches **700 Series**

721/2/3, 731/2/3/4,
771/2/3/4 & 781
Issue G

- Precision stainless steel mechanism for arduous atmospheres and high humidity.
- Set point adjustable over whole range against calibrated scale with tamperproof adjuster.
- Weatherproof and Flameproof models.
- Models for fixed switching differential, adjustable differential and HI-LO operation.
- Hermetically sealed microswitch option.
- ATEX and IECEx



Performance **characteristics**

Enclosure

- IP66 Protection

System options

- Stainless Steel capillary system and Brass Bellows (standard)
- Stainless Steel capillary system and Bellows
- Rigid stem.

Standard Electrical ratings

- Refer to table 6

Process connection

- 3/8 NPT External Sliding Gland, 1/2 NPT External Direct mounting.

Unit weight

- Between 2.2kg – 8.7kg (4.8lb – 19.1lb)

Accuracy

- Set point repeatability $\pm 0.5\%$ of span at 20 °C / 68 °F ambient.
- Scale accuracy $\pm 2\%$ of full scale.

Product **applications**

The 721 is suitable for a wide range of applications in many Industry sectors:

- Oil & Gas
- Chemical
- Petrochemical
- Refining
- Power
- Food Industry

The choice of models available ensures that the 721 is suitable for use in:

- Corrosive atmospheres
- Resistant to chemical attack

How can we **help you?**

Delta Controls' range of reliable pressure and temperature measurement instruments can be customised to meet individual requirements. For technical advice or to discuss your application please contact us on +44 (0) 20 8939 3500

Enclosure

FINISH

All enclosures except Type A are finished in light grey epoxy resin paint. Special finishes to order.

INTRINSIC SAFETY

Because of the low voltages and currents of I.S. circuits, we recommend using gold and/or sealed contacts.

NOTE: Enclosure K is not recommended on models 731/2/3/4, because of weight limitation on stem mounting.

Enclosure code A is recommended for use with System Codes E, F, G, H, T. (See Table 4.)

TABLE 1
TABLE 1

WEATHERPROOF ENCLOSURES	Code
General Purpose The basic enclosure is pressure die-cast in zinc alloy, offering weather protection not less than NEMA 4 + 13/IP66.	W
For Aggressive Atmospheres Investment cast enclosure in austenitic stainless steel with weather protection not less than NEMA 4X + 13/IP66.	A
FLAMEPROOF ENCLOSURES CATEGORY 2 (ZONE 1)	
EExd IIC T6 (-60 to +40°C), T4 (-60 to +80°C) II 2 G D Gravity die-cast enclosure in aluminium-silicon alloy, certified to CENELEC EN50 014 and EN50 018. II 2 G D Suitable for outdoor use, IP66 / NEMA 4	H
IECEX ExdIIC certified to IEC 60079-0 and certified by IEC60079-1	
EExd IIC T6 (-60 to +40°C), T4 (-60 to +80°C) II 2 G D As Code H, but sand cast in high quality grey iron.	K
IECEX ExdIIC certified to IEC 60079-0 and IEC 60079-1	
EExn ENCLOSURES CATEGORY 3 (ZONE 2)	
Type of Protection EExn II T6 (-20 to +40°C) II 3 G As code 'W' but EExn to EN50021. Weatherproof to NEMA 4/IP66. II 2 G D Limited switching facility (see table 6)	N
As 'N' but with investment cast enclosure in austenitic stainless steel as 'A'.	O

Models

For model and range availability see Tables 5A and 5B. Gas filled models offer range -50 to +150°C (-60 to +360°F) span 200 deg. C (420 deg. F) and a maximum working temperature of 250°C (480°F).

Models 771-4 is only available with armoured capillary systems.

Models 731-4 are not available with ranges above 120°C (250°F). Limitation due to heat conduction, causing an unacceptable rise in temperature at the head.

TABLE 2
TABLE 2

Model – and System Type	Vapour pressure rigid stem	Vapour pressure flexible thermal system
Fixed Switching Differential. See Tables 10A and 10C. Basic model giving close, fixed switching differential using proprietary microswitch operated by high integrity stainless steel mechanism. Set point field adjustable over full range against calibrated scale. SPDT & DPDT options available.	721	771
Adjustable Switching Differential. (Limited Span). See Tables 10B & 10D. Achieved by special microswitch with built in adjuster, SPDT only. Not available with enclosure code N or O.	722	772
Adjustable Switching Differential (Wide Span). See Tables 10B & 10D. Falling set point adjustable against a calibrated scale. Rising reset point adjustable to increase switching differential by up to 50% of range.	723	773
HI-LO Switching (Adjustable Gap). See Tables 10A & 10C Two individual set points and separate electrical circuits, with independent adjustment against scale. Each switch may be SPDT only.	781	774

Electrical Entry

Adaptors are available for other popular thread sizes.

Enclosures 'W' and 'N'

Standard option code 1 (22mm dia) is provided with a nylon 22/20 reducer and fibre washer suitable for a standard M20 cable gland and back nut. Option code 0 elbow adaptor is factory fitted. Adapter kits may also be provided retrospectively to fit at site if required. Ask for details. See diagram in DIMENSIONS

'W' and 'N' SAFETY NOTE

If a metal cable gland is site fitted it must either be earthed locally or an earth/gland plate must be used to connect the body of the gland at the enclosure earthing point. Earth/gland plates can be provided either factory fitted or in kit form for site assembly.

TABLE 3

	Code
Enclosure W & N: Clearance for 20mm (3/4 in) outside dia conduit.	1
Enclosures H, K & A: M20 x 1.5 ISO thread.	0
Enclosures H & K: M20 x 1.5 ISO thread, dual entry.	5
Enclosures H & K: 3/4-NPT INT.	3
Enclosures H & K: 3/4-NPT INT. dual entry	6
Enclosure W: M20 x 1.5 elbow adaptor.	0
Enclosure N: M20 x 1.5 straight adaptor (Approved).	0

System Details

TABLE 4

The flexible thermal system of Models 721-3, 771-4 & 781 comprises an armoured capillary attached to the sensing bulb via a semi-rigid extension on which a compression gland slides to enable various depths of thermowell (pocket) to be accommodated. See DIMENSIONS.

All parts of the thermal system are in 300 series stainless steel with the capillary sensing bulb and armour in 316 stainless steel.

The thermal systems of Models 731-4 comprises a rigid stem attached to the sensing bulb by an extension on which a compression gland slides to accommodate various attachments the gland has a 1/2 – 14NP external thread. The rigid stem version has probe materials of 316 stainless steel.

Models 721-3, 771-4, 781

Capillary Length †		Length of Semi-rigid Stem †		Stainless Steel System & Brass Bellows	Stainless Steel System & Bellows
Metres	Feet	mm	inches	Code	Code
3	10	250	10	A	E
3	10	500	20	B	F
6	20	250	10	C	G
6	20	500	20	D	H

† Other lengths are available to order.

Models 731-4	Code
Rigid stem 250mm (10in) long x 12mm (0.47in) dia Stainless steel Rigid Stem & brass bellows	S
Rigid stem 250mm (10in) long x 12mm (0.47in) dia Stainless steel Rigid Stem & bellows	T

Setting Ranges

TABLE 5

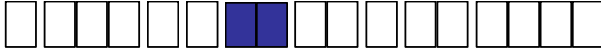

Table 5A – Deg C

T_{max} = maximum working temperature

NOTE: All models have a bulb diameter of 12mm (0.47in).

Models 721-3, 731-4 and 781 have a bulb length of 80mm (3.2in).

Models 771-4 have a bulb length of 140mm (5.5in).

Availability			Range	T_{max}	Code
721-3 781	731-4	771-4			
✓	✓	-	-50 to +5	35	B1
-	-	✓	-50 to +150	250	M1
✓	✓	-	-5 to +65	75	H2
✓	✓	-	20 to 90	95	J1
✓	✓	-	50 to 120	130	L4
✓	-	-	100 to 170	180	Q4
✓	-	-	150 to 220	230	S5
✓	-	-	190 to 260	270	U6
✓	-	-	230 to 300	310	V7

Table 5B – Deg F

Availability			Range	T_{max}	Code
721-3 781	731-4	771-4			
✓	✓	-	-50 to +40	75	BF
-	-	✓	-60 to +300	480	MF
✓	✓	-	20 to 150	170	HB
✓	✓	-	70 to 200	203	JF
✓	✓	-	120 to 250	270	LB
✓	-	-	210 to 340	360	QA
✓	-	-	300 to 430	450	SF
✓	-	-	370 to 500	520	UB
✓	-	-	450 to 580	600	VB

Switching Options

TABLE 6

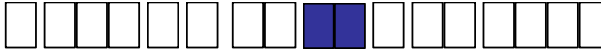

A much wider variety of switching options can be engineered to customer's requirements for Model 721, 731, 771 temperature switches, manual latching, pneumatic output etc. Please consult our engineers for further information.

Model 721, 731, 771									
UL/CSA Rating (RESISTIVE) §SEE NOTE	IEC 947-5-1/EN 60947-5-1 Rating							Contact	Code
	Designation & Utilization Category	Rated operational current I _e (A) at rated operational voltage U _e	U _i	U _{imp}	VA Rating				
					Make	Break			
5 Amps @ 110/250V AC Light Duty for AC only	AC14 D300	0.6/0.3A @ 120/240V AC	250V	0.8kV	432	72	SPDT DPDT	00 01	
	DC13 R300	0.22/0.1A @ 125/250V DC			28	28			
5 Amps @ 110/250V AC & 2 Amps @ 30V DC General purpose precision	AC14 D300	0.6/0.3A @ 120/240V AC	250V	0.8kV	432	72	SPDT DPDT	02 03	
	DC13 R300	0.22/0.1A @ 125/250V DC			28	28			
1 Amp @ 125V AC & §100mA @ 30V DC gold alloy contacts for low voltage switching	1 A @ 125 VAC RESISTIVE (IEC 1058-1/EN 61058-1)						SPDT DPDT	04 05	
§ 5 Amps @ 110/250V AC & 5 Amps @ 30V DC Environmentally sealed.	AC14 D300	0.6/0.3A @ 120/240V AC	250V	0.5kV	432	72	SPDT* DPDT*	08 09	
	DC13 R300	0.22/0.1A @ 125/250V DC			28	28			
§ 1 Amp @ 30V AC & 30V DC Environmentally sealed with gold contacts	AC14 E150	0.3A @ 120V AC	125V	0.5kV	216	36	SPDT* DPDT*	0G 0H	
5 Amps @ 250V AC and 2 Amps @ 30V DC Hermetically sealed. Gold plated silver contacts.	AC14 D300 DC13 R300	0.6/0.3A @ 120/240V AC 0.22/0.1A @ 125/250V DC	250V	0.5kV	432 28	72 28	SPDT DPDT	H2 H3†, H6‡	
† 2 Single pole, double throw, simultaneous falling under pressure									
‡ 2 Single pole, double throw, simultaneous rising under pressure.									
Model 722, 732, 772 (Cannot be supplied with enclosure Code N)									
5 Amps @ 110/250V AC Light Duty for AC only	AC14 D300	0.6/0.3A @ 120/240V AC	250V	0.8kV	432	72	SPDT	OC	
5 Amps @ 110/250V AC and 2 Amps @ 30V DC Adjustable	AC14 D300 DC13 R300	0.6/0.3A @ 120/240V AC 0.22/0.1A @ 125/250V DC	250V	0.8kV	432 28	72 28	SPDT	OD	
Model 723, 733, 773									
5 Amps @ 110/250V AC & 2 Amps @ 30V DC General purpose precision	AC14 D300	0.6/0.3A @ 120/240V AC	250V	0.8kV	432	72	SPDT DPDT	02 03	
	DC13 R300	0.22/0.1A @ 125/250V DC			28	28			
1 Amp @ 125V AC & §100mA @ 30V DC gold alloy contacts for low voltage switching	1 A @ 125 VAC RESISTIVE (IEC 1058-1/EN 61058-1)						SPDT DPDT	04 05	
Model 734, 774, 781									
5 Amps @ 110/250V AC Light Duty for AC only	AC14 D300	0.6/0.3A @ 120/240V AC	250V	0.8kV	432	72	SPDT	20	
	DC13 R300	0.22/0.1A @ 125/250V DC			28	28			
5 Amps @ 110/250V AC & 2 Amps @ 30V DC General purpose precision	AC14 D300	0.6/0.3A @ 120/240V AC	250V	0.8kV	432	72	SPDT	22	
	DC13 R300	0.22/0.1A @ 125/250V DC			28	28			
1 Amp @ 125V AC & §100mA @ 30V DC gold alloy contacts for low voltage switching	1 A @ 125 VAC RESISTIVE (IEC 1058-1/EN 61058-1)						SPDT	24	
§ 5 Amps @ 110/250V AC & 5 Amps @ 30V DC Environmentally sealed.	AC14 D300 DC13 R300	0.6/0.3A @ 120/240V AC 0.22/0.1A @ 125/250V DC	250V	0.5kV	432 28	72 28	SPDT*	28	
§ 1 Amp @ 30V AC & 30V DC Environmentally sealed with gold contacts	AC14 E150	0.3A @ 120V AC	125V	0.5kV	216	36	SPDT*	2G	
5 Amps @ 250V AC and 2 Amps @ 30V DC Hermetically sealed. Gold plated silver contacts.	AC14 D300 DC13 R300	0.6/0.3A @ 120/240V AC 0.22/0.1A @ 125/250V DC	250V	0.5kV	432 28	72 28	SPDT	H4	
<p>The electrical rating is dependent on the microswitch fitted to the instrument. The electrical ratings defined by each approval that the microswitch complies with and is shown on the product nameplate, ie UL/CSA, or IEC. It should be noted that the instrument must be used within the electrical rating specified from the approval you require. This table lists the actual IEC ratings against the Designation & Utilization Category marked on the nameplates. In the absence of any verification by UL/CSA the microswitch § manufacturer's rating is stated in italics and bold. If in doubt seek guidance from the factory.</p> <p>NOTE: For low energy circuits e.g. 30V and up to 100mA, we recommend using gold alloy contact switches. U_i = rated insulation voltage U_{imp} = rated impulse withstand voltage across contacts.</p>									
*Suitable for use with EExn Enclosures (Code N)									

Process Connection

Adaptors to other threads are available as optional extras.

Other thread specifications and sizes are available without using adaptors. See DIMENSIONS

TABLE 7

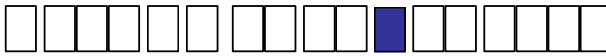

	Code
3/8 –18 NPT EXT Sliding Gland (System Code A to H Table 4)	E
1/2 – 14NPT EXT Sliding Gland (System Code S, T Table 4)	J

Options & Treatments

Combinations available, apply for details.

NOTE: Use stainless steel system codes E, F, G, H, T (Table 4) only with Marine & Ammonia codes 02, 03 and capillary codes A, B, C, D, E, F, G, H (Table 4) only with pipe mounting bracket code 10.

TABLE 8

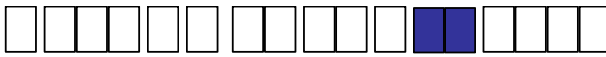

	Code
Tropicalisation High humidity environment	01
Marine and Offshore Saline atmosphere or salt spray	02
Ammonia Process (wetted) parts and construction suitable for atmospheric ammonia.	03
Oxygen Service 2: Process (wetted) parts are cleaned for oxygen.	04
Oxygen Service3: Process and non-process parts are cleaned for use with oxygen.	05
Stainless Steel Pipe Mounting Bracket Permits local 2" pipe work to be utilised for mounting the instrument.	10
Tagging - Variety of tagging methods are available	APPLY FOR DETAILS
Applies when – no option is required and selection is made from special engineering.	00

Special Engineering

TABLE 9



FEATURE	Code
Please consult Delta sales engineering for special requirements.	TBA

THERMOWELLS

Material 316SS.
Maximum Working Pressure
140bar (2000psi) at 20°C

Thermowells can also be manufactured to customers own drawing/specification requirements.

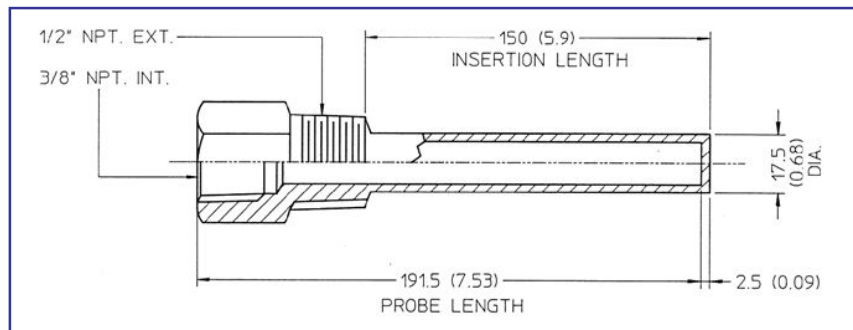

Performance Data

TABLE 10

Celsius Units (°C)

**TABLE 10A
FIXED SWITCHING DIFFERENTIAL**

Models 734, 774, 781 the switching differential on each point may be up to 1.5 times that of Table 10A & 10C. Care must be exercised, therefore, in specifying high differential switches or set point separation less than 3 times switching differential.

MODELS 721, 731, (734), 771, (774), (781)											
Code	Range	SPDT OPTIONS					DPDT OPTIONS (721 / 731 ONLY)				
		00 (20)	02 (22)	04 (24)	08/0G (28/2G)	H2 (H4)	01	03	05	09/0H	H3/H6
B1	-50 to +5	2	4	2	8	11	4	6	4	12	16
M1	-50 to 150	3	5.5	3	11	11	5.5	28	5.5	20	16
H2	-5 to +65	1	2	1	4	5.5	2	4	2	6	8
J1	20 to 90	1	2	1	4	5.5	2	4	2	6	8
L4	50 to 120	1	2	1	4	5.5	2	4	2	6	8
Q4	100 to 170	1.5	3	1.5	6	8	3	5	3	9	12
S5	150 to 220	1.5	3	1.5	6	8	3	5	3	9	12
U6	190 to 260	2	4	2	8	10	4	6	4	12	15
V7	230 to 300	2	4	2	8	10	4	8	4	12	15

**TABLE 10B
ADJUSTABLE SWITCHING DIFFERENTIAL**

MODELS 722, 723, 732, 733, 772, 773										
Code	Range	722, 732, 772				723, 733, 773				
		SPDT Only				SPDT Options		DPDT Options		
		0C		0D		02 or 04		03 or 05		
		Min	Max	Min	Max	Min	Max	Min	Max	
B1	-50 to +5	2	4	3.5	8	10	30	15	30	
M1	-50 to 150	3	5.5	5	11	30	100	40	100	
H2	-5 to +65	1.5	4	3	7	10	30	15	30	
J1	20 to 90	1.5	4	3	7	10	30	15	30	
L4	50 to 120	1	3.5	2.5	7	10	30	15	30	
Q4	100 to 170	1.5	4	3	7	10	30	15	30	
S5	150 to 220	1.5	4	3	7	10	30	15	30	
U6	190 to 260	2	4	3.5	8	10	30	15	30	
V7	230 to 300	2	4	3.5	8	10	30	15	30	

Fahrenheit Units (°F)

**TABLE 10C
FIXED SWITCHING DIFFERENTIAL**

MODELS 721, 731, (734), 771, (774), (781)											
Code	Range	SPDT OPTIONS					DPDT OPTIONS (721 / 731 ONLY)				
		00 (20)	02 (22)	04 (24)	08/0G (28/2G)	H2 (H4)	01	03	05	09/0H	H3/H6
BF	-50 to +40	3.5	7	3.5	15	20	7	11	7	22	29
MF	-60 to 300	5	10	5	20	20	10	20	10	30	29
HB	20 to 150	2	3.5	2	7	10	3.5	7	3.5	11	14
JF	70 to 200	2	3.5	2	7	10	3.5	7	3.5	11	14
LB	120 to 250	2	3.5	2	7	10	3.5	7	3.5	11	14
QA	210 to 340	3	5.5	3	11	14	5.5	9	5.5	16	22
SF	300 to 430	3	5.5	3	11	14	5.5	9	5.5	16	22
UB	370 to 500	3.5	7	3.5	15	18	7	11	7	22	27
VB	450 to 580	3.5	7	3.5	15	18	7	15	7	22	27

**TABLE 10D
ADJUSTABLE SWITCHING DIFFERENTIAL**

Due to manufacturing tolerances, the figures quoted in these tables are for guidance only. Should the differential be critical for specific applications, our engineers should be consulted prior to ordering.

Flameproof models may be up to 2 times higher depending on the range. Should the differential be critical for specific applications our engineers should be consulted prior to ordering.

MODELS 722, 723, 732, 733, 772, 773										
Code	Range	722, 732, 772				723, 733, 773				
		SPDT Only				SPDT Options		DPDT Options		
		0C		0D		02 or 04		03 or 05		
		Min	Max	Min	Max	Min	Max	Min	Max	
BF	-50 to +40	3.5	7	6.5	14	18	54	27	54	
MF	-60 to 300	5	10	10	20	60	180	70	180	
HB	20 to 150	3	7	5.5	12	18	54	27	54	
JF	70 to 200	3	7	5.5	12	18	54	27	54	
LB	120 to 250	2	6	4.5	12	18	54	27	54	
QA	210 to 340	3	7	5.5	12	18	54	27	54	
SF	300 to 430	3	7	5.5	12	18	54	27	54	
UB	370 to 500	3.5	7	6.5	14	18	54	27	54	
VB	450 to 580	3.5	7	6.5	14	18	54	27	54	

Technical Specifications

ACCURACY

Set point repeatability $\pm 0.5\%$ of full scale at 20°C ambient.
Scale accuracy $\pm 2\%$ of full scale.

NOTE: For models 721-3, 781 scale accuracy will be affected by relative position of head and sensing bulb i.e., sensing bulb 1 metre above/below head = set point shift minus/plus 1% of full scale approx.

AMBIENT TEMPERATURE RANGE

All models are suitable for operating within a range of ambient temperature from -25 to +60°C (-13 to +140°F).

Models 771-4. A 10 deg Celsius (18 deg F) rise in ambient temperature will on average result in a 1 deg (Celsius 1.8 deg F) fall in set point.

ELECTRICAL CONNECTIONS

Terminal Block

Cable entry is to a non-pinching block made of a non-hygroscopic thermosetting plastic, suitable for cables up to 2.5mm²/14AWG.

Earthing/Grounding

An earthing stud is provided inside all weatherproof enclosures, adjacent to the entry. External earthing is standard on flameproof versions.

'W' and 'N' Safety Note

If a metal cable gland is site fitted it must either be earthed locally or an earth/gland plate must be used to connect the body of the gland at the enclosure earthing point. Earth/gland plates can be provided either factory fitted or in kit form for site assembly. Ask for details. See diagrams in DIMENSIONS.

Dielectric Strength

The electrical assembly is capable of withstanding *2kV between live parts and earth/ground and 500V between open contacts.

*1.2kV for micro switch Codes H2, H3, H4 and H6. Refer to Table 6.

Electrical Entry

Standard options are listed in Table 3. Other threads can be accommodated by adaptors. Dual entry available on some enclosures.

MAXIMUM WORKING PRESSURE

System sensing probes for both the capillary and rigid stem version are designed to withstand 100bar (1500psi) without thermowell.

Mounting

Position/Location/Installation

Vertical as shown, in **dimensions**, taking care to avoid siting in locations that transmit excessive shock or vibration. For further advice contact our engineers.

Pollution degree (EN60947-5-1)

All products are suitable for use in pollution degree 3. For extreme conditions where condensation may readily form, then sealed contacts should be used. See Table 6 codes 08/09, 0G/0H, 2G/28, H2/H3/H4/H6.

Electrical Isolation – These products are not suitable for electrical isolation. Always isolate circuit separately to carry out any electrical work.

NOTE: On models 721-3, 781 it is advisable to avoid the condition where the ambient temperature is within ± 5 deg Celsius (± 9 deg F) of the set point. Under this condition the liquid/vapour phase becomes less well defined and the switching differential increases. Where this condition is unavoidable refer to Models 740/760 Liquid Expansion Temperature Switches or 771-4.

Unit Weights

UNIT WEIGHTS (approx)		
ENCLOSURES	MODELS 721-3, 771-4, 781	MODELS 731-4
'W' & 'N'	2.5kg/5.5lb	2.2kg/4.8lb
'A' & 'O'	3.5kg/7.7lb	3.2kg/7.0lb
'H'	4.0kg/8.8lb	N/A
'K'	8.7kg/19.1lb	N/A

Approvals

CENELEC / ATEX II 2 G D (Enclosure Codes H and K and all models).
 Certified to CENELEC EN50 014, EExd IIC T6 (-60 to +40°C), EExd IIC T4 (-60 to +80°C) EN50 018, EN50 021-1-1 (DUST), EN5028-1-1 (DUST)
 For use in Zone 1 hazardous areas. Category 2.

Certificate number BASOIATEX2426X



IECEx APPROVAL for use in Zone 1 hazardous areas
 Exd IIC certified to IEC 60079-0 and IEC60079-1
 Cert No. IECExITS04 0006X

Dimensions

All dimensions mm (inches)

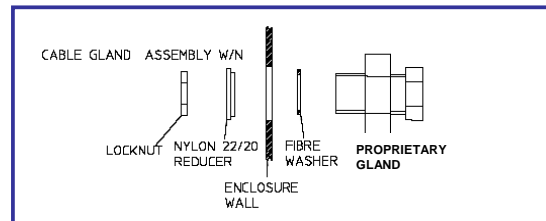
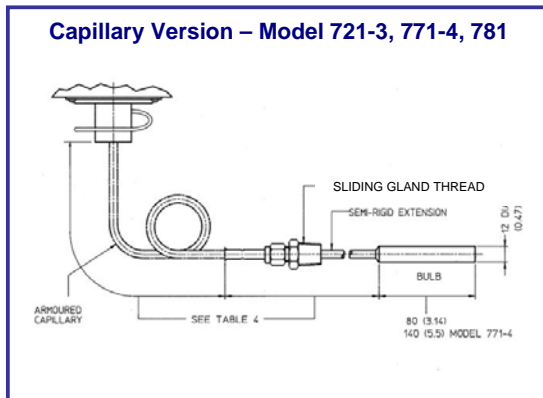
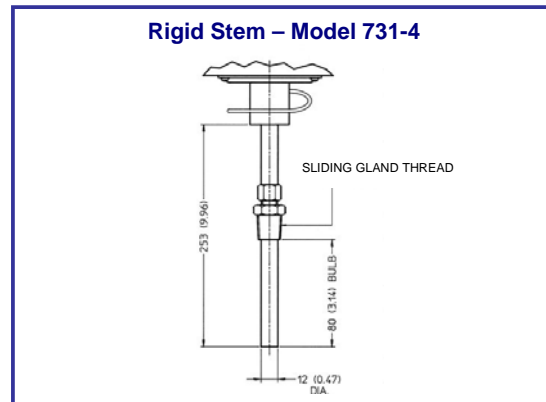
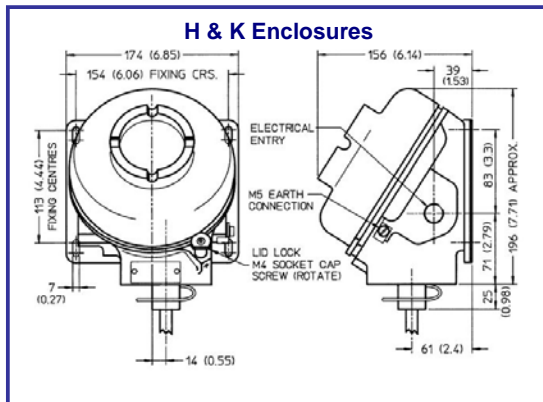
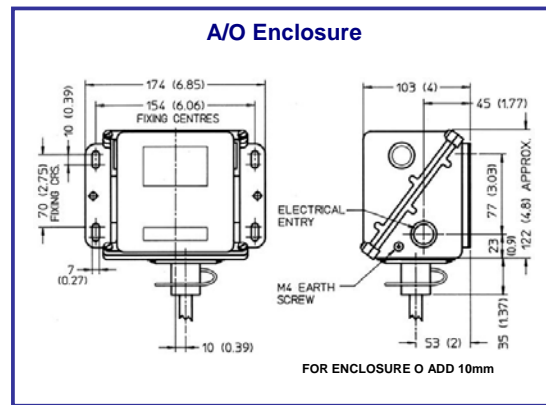
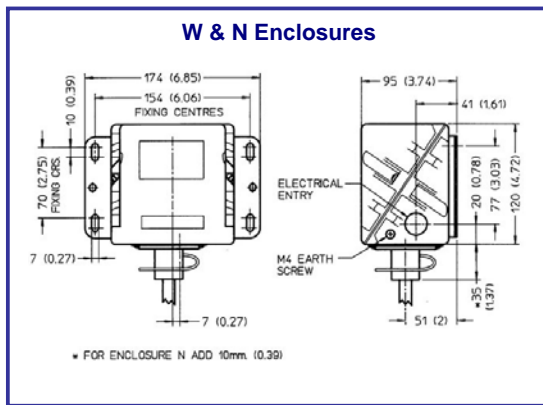

In the interest of development and improvement Delta Controls Ltd, reserves the right to amend, without notice, details contained in this publication. Delta Controls Ltd will accept no legal liability for any errors, omissions or amendments.



Delta Controls Limited

Island Farm Avenue, West Molesey, Surrey KT8 2UZ, UK.

T+44 (0)20 8939 3500 F+44 (0)20 8783 1163 [E sales@delta-controls.com](mailto:sales@delta-controls.com) [W www.delta-controls.com](http://www.delta-controls.com)

