

Performance Diaphragm Operated Pressure Difference Switches **306 / 386 Models**

**306 / 386
Issue L**

- Precision stainless steel mechanism for arduous atmospheres and high humidity.
- Static pressure up to 15 bar (200 psi), and ranges down to +/- 0.6 mbar (+/- 0.25 in.H₂O).
- Set point adjustable over whole range against calibrated scale with tamperproof adjuster
- Weatherproof and Flameproof models – ATEX and IECEx.
- Models for fixed switching differential, adjustable differential and HI-LO operation.
- Safety vented or blow out device as standard.
- Hermetically sealed microswitch option.

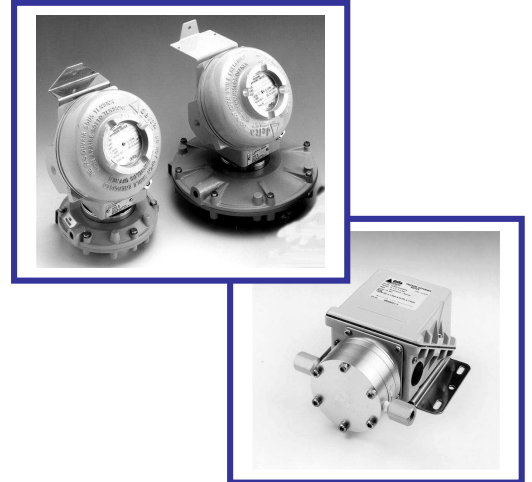

Performance characteristics

Enclosure

- IP66 Protection

Wetted parts options

- Nitrile diaphragm & seal. Aluminium alloy flanges.
- Nitrile diaphragm & seal. Cast iron flanges

Standard Electrical ratings

- Refer to table 6

Process connection

- Rc ¼ (BSP).

Unit weight

- Between 1.7kg – 3.74kg (3.7lb – 8.1lb)

Accuracy

- Set point repeatability ± 1% of span at 20 °C / 68 ° F ambient.
- Scale accuracy ± 3% of full scale.

Product applications

The 306 / 386 is suitable for a wide range of applications in many Industry sectors:

- Oil & Gas
- Chemical
- Petrochemical
- Refining
- Power
- Food Industry

The choice of models available ensures that the 306 / 386 is suitable for use in:

- Corrosive atmospheres
- Resistant to chemical attack

How can we help you?

Delta Controls' range of reliable pressure and temperature measurement instruments can be customised to meet individual requirements. For technical advice or to discuss your application please contact us on +44 (0) 20 8939 3500

Enclosure

FINISH

All enclosures are finished in light grey epoxy resin paint – Except type A.

INTRINSIC SAFETY

Because of the low voltages and currents of I.S. circuits, we recommend using gold and/or sealed contacts.



Since Model 306 is not normally intended for corrosive media and atmospheres the stainless steel 'A' enclosure (available on Models 301/304/381) is provided only as a special

NOTE: *In the interest of safety and availability, not all enclosures are available with all wetted part materials. See Table 4.*

Temperatures in Table 1 refer to limitations for certified enclosures. See **TECHNICAL DATA**.

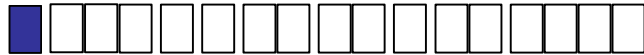
TABLE 1



WEATHERPROOF ENCLOSURES	Code
General Purpose The basic enclosure is pressure die-cast in zinc alloy, offering weather protection not less than NEMA 4 + 13/IP66.	W
For Aggressive Atmospheres Investment cast enclosure in austenitic stainless steel with weather protection not less than NEMA 4X + 13/IP66.	A
FLAMEPROOF ENCLOSURES CATEGORY 2 (ZONE 1)	
EExd IIC T6 (-60 to + 40°C), T4 (-60 to +80°C) II 2 G D Gravity die-cast enclosure in aluminium-silicon alloy, certified to CENELEC EN50 014 and EN50 018.  Suitable for outdoor use, IP66 / NEMA 4	H
IECEx ExdIIC certified to IEC 60079-0 and certified by IEC60079-1	
EExd IIC T6 (-60 to + 40°C), T4 (-60 to +80°C) II 2 G D As Code H, but sand cast in high quality grey iron. 	K
IECEx ExdIIC certified to IEC 60079-0 and IEC 60079-1	
EExn ENCLOSURES CATEGORY 3 (ZONE 2)	
Type of Protection EExn II T6 (-20 to +40°C) II 3 G As code 'W' but EExn to EN50021. Weatherproof to NEMA 4/IP66. Limited switching facility (see table 6)	N
As 'N' but with investment cast enclosure in austenitic stainless steel as 'A'.	O

Models

TABLE 2



	Code
Fixed Switching Differential. See tables 10A and 10B. Basic model giving close, fixed switching differential using proprietary microswitch operated by high integrity stainless steel mechanism. Set point field adjustable over full range against a calibrated scale. SPDT & DPDT options available.	306
HI-LO Switching (Adjustable Gap). See tables 10A & 10B. Two individual set points, with independent adjustment against a calibrated scale.	386

Electrical Entry

Adaptors are available for other popular thread sizes.

Enclosures 'W' and 'N'

Standard option code 1 (22mm dia) is provided with a nylon 22/20 reducer and fibre washer suitable for a standard M20 cable gland and back nut. Option code 0 elbow adaptor is factory fitted. Adapter kits may also be provided retrospectively to fit at site if required. Ask for details. See diagram in DIMENSIONS

'W' and 'N' SAFETY NOTE

If a metal cable gland is site fitted it must either be earthed locally or an earth/gland plate must be used to connect the body of the gland at the enclosure earthing point. Earth/gland plates can be provided either factory fitted or in kit form for site assembly. Ask for details.

TABLE 3

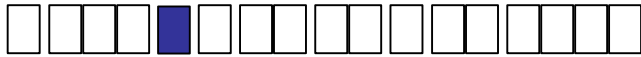

	Code
Enclosures W & N: Clearance for 20mm (3/4 in) outside dia conduit.	1
Enclosures H & K: 20mm x 1.5 ISO thread.	0
Enclosures H & K: 3/4-NPT INT	3
Enclosures N: M20 x 1.5 straight adaptor. (Approved.)	0

Material of Wetted Parts

TABLE 4

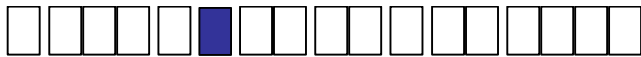

MATERIAL	AVAILABILITY		Code
	Enclosure	Range	
Nitrile diaphragm & seal, aluminium alloy flanges.	W, H, N	ALL	D
Nitrile diaphragm & seal. Cast iron flanges.	K	B2, B3, B5, C6	E

Setting Ranges

TABLE 5



P_{max} = maximum working pressure

NOTE: For pressure difference switches P_{max} and maximum static/line pressure mean the same.

P_{max}		RANGE			Code
bar	psi	mbar / bar	Code	in. H ₂ O / psi	
0.5	7	-0.6 to +0.6	B2	-0.25 to +0.25	B6
1	15	-2.5 to +2.5	B3	-1 to +1	BN
1	15	0 to 5	B5	0 to 2	BR
1	15	-12.5 to +12.5	BC	-5 to +5	BU
1	15	3 to 25	C6	1 to 10	CP
15	200	5 to 120	E1	2 to 50	E4
15	200	50 to 350	E8	1 to 5	E7
15	200	0.1 to 1.5	G5	1 to 20	GP
15	200	0.2 to 4	J0	2 to 60	J3

Switching Options

TABLE 6

On models 306 & 386 only the switching options specified can be supplied. Please consult our engineers for further information.

Model 306									
UL/CSA Rating (RESISTIVE) §SEE NOTE	IEC 947-5-1/EN 60947-5-1 Rating							Contact	Code
	Designation & Utilization Category	Rated operational current I _e (A) at rated operational voltage U _e	U _i	U _{imp}	VA Rating				
					Make	Break			
5 Amps @ 110/250V AC Light Duty for AC only	AC14 D300	0.6/0.3A @ 120/240V AC	250V	0.8kV	432	72	SPDT DPDT	00 01	
	DC13 R300	0.22/0.1A @ 125/250V DC			28	28			
5 Amps @ 110/250V AC & 2 Amps @ 30V DC General purpose precision	AC14 D300	0.6/0.3A @ 120/240V AC	250V	0.8kV	432	72	SPDT DPDT	02 03	
	DC13 R300	0.22/0.1A @ 125/250V DC			28	28			
1 Amp @ 125V AC & §100mA @ 30V DC gold alloy contacts for low voltage switching	1 A @ 125 VAC RESISTIVE (IEC 1058-1/EN 61058-1)						SPDT DPDT	04 05	
§ 5 Amps @ 110/250V AC & 5 Amps @ 30V DC Environmentally sealed.	AC14 D300	0.6/0.3A @ 120/240V AC	250V	0.5kV	432	72	SPDT* DPDT*	08 09	
	DC13 R300	0.22/0.1A @ 125/250V DC			28	28			
§ 1 Amp @ 30V AC & 30V DC Environmentally sealed with gold contacts	AC14 E150	0.3A @ 120V AC	125V	0.5kV	216	36	SPDT* DPDT*	0G 0H	
5 Amps @ 250V AC and 2 Amps @ 30V DC Hermetically sealed. Gold plated silver contacts.	AC14 D300	0.6/0.3A @ 120/240V AC	250V	0.5kV	432	72	SPDT DPDT	H2 H3†, H6‡	
	DC13 R300	0.22/0.1A @ 125/250V DC			28	28			
† 2 Single pole, double throw, simultaneous falling under pressure ‡ 2 Single pole, double throw, simultaneous rising under pressure.									
Model 386									
5 Amps @ 110/250V AC Light Duty for AC only	AC14 D300	0.6/0.3A @ 120/240V AC	250V	0.8kV	432	72	SPDT	20	
	DC13 R300	0.22/0.1A @ 125/250V DC			28	28			
5 Amps @ 110/250V AC & 2 Amps @ 30V DC General purpose precision	AC14 D300	0.6/0.3A @ 120/240V AC	250V	0.8kV	432	72	SPDT	22	
	DC13 R300	0.22/0.1A @ 125/250V DC			28	28			
1 Amp @ 125V AC & §100mA @ 30V DC gold alloy contacts for low voltage switching	1 A @ 125 VAC RESISTIVE (IEC 1058-1/EN 61058-1)						SPDT	24	
§ 5 Amps @ 110/250V AC & 5 Amps @ 30V DC Environmentally sealed.	AC14 D300	0.6/0.3A @ 120/240V AC	250V	0.5kV	432	72	SPDT*	28	
	DC13 R300	0.22/0.1A @ 125/250V DC			28	28			
§ 1 Amp @ 30V AC & 30V DC Environmentally sealed with gold contacts	AC14 E150	0.3A @ 120V AC	125V	0.5kV	216	36	SPDT*	2G	
5 Amps @ 250V AC and 2 Amps @ 30V DC Hermetically sealed. Gold plated silver contacts.	AC14 D300	0.6/0.3A @ 120/240V AC	250V	0.5kV	432	72	SPDT	H4	
	DC13 R300	0.22/0.1A @ 125/250V DC			28	28			
The electrical rating is dependent on the microswitch fitted to the instrument. The electrical ratings defined by each approval that the microswitch complies with and is shown on the product nameplate, ie UL/CSA, or IEC. It should be noted that the instrument must be used within the electrical rating specified from the approval you require. This table lists the actual IEC ratings against the Designation & Utilization Category marked on the nameplates. In the absence of any verification by UL/CSA the microswitch § manufacturer's rating is stated in italics and bold . If in doubt seek guidance from the factory.									
NOTE: For low energy circuits e.g. 30V and up to 100mA, we recommend using gold alloy contact switches.									
U _i = rated insulation voltage U _{imp} = rated impulse withstand voltage across contacts.									
*Suitable for use with EExn Enclosures (Code N)									

Process Connection

TABLE 7

Adaptors are available for applications where their use is permitted.

	Code
Rc 1/4 (1/4 BSP tr INT) to (ISO 7/1)	A

Options & Treatments

TABLE 8



Combinations available, apply for details.

	Code
Tropicalisation High humidity environment	01
Ammonia Process (wetted) parts and construction suitable for atmospheric ammonia.	03
Stainless steel pipe mounting bracket permits local 2" pipework to be utilised for mounting the instrument.	10
Tagging – Variety of tagging methods are available.	APPLY FOR DETAILS
Applies when – no option is required and selection is made from special engineering	00

Special Engineering

TABLE 9



FEATURE	Code
Please consult Delta sales engineering for special requirements.	TBA

Performance Data

TABLE 10

Bar Units (SI)

MODEL 306, (386)

mbar units

TABLE 10A

TABLE 10A MODELS 306, 386

MODEL 386: The switching differential on each point may be up to 1.5 times that of Table 10A & 10B. Care must be exercised, therefore, in specifying high differential switches on sensitive ranges, or set point separation less than 3 times switching differential.

Range code	Range mbar / bar	SPDT Options					DPDT Options				
		00 (20)	02 (22)	04 (24)	08/0G (28/2G)	H2 (H4)	01	03	05	09/0H	H3/H6
B2	-0.6 to +0.6	0.2	0.2	0.2	-	-	0.4	0.4	0.5	-	-
B3	-2.5 to +2.5	0.4	0.8	0.4	0.8	-	0.8	1.2	0.8	1.2	-
B5	0 to 5	0.4	0.8	0.4	1.5	1.2	0.8	1.2	0.8	1.7	1.8
BC	-12.5 to +12.5	0.5	1.0	0.5	10	10	1.0	2.0	1.0	12	15
C6	3 to 25	0.5	1.0	0.5	10	10	1.0	2.0	1.0	12	15
E1	5 to 120	8	24	8	40	40	15	32	16	45	60
E8	50 to 350	25	75	25	44	44	50	100	50	50	64
G5	0.1 to 1.5	50	150	50	200	200	100	200	100	250	290
J0	0.2 to 4	150	450	150	600	600	300	600	300	700	840

PSI Units

MODEL 306, (386)

psi units

TABLE 10B

TABLE 10B MODELS 306, 386 FIXED SWITCHING DIFFERENTIAL

Due to manufacturing tolerances the figures quoted in these tables are for guidance only and are typical for weatherproof models.

Range code	Range in. H ₂ O / psi	SPDT Options					DPDT Options				
		00 (20)	02 (22)	04 (24)	08/0G (28/2G)	H2 (H4)	01	03	05	09/0H	H3/H6
B6	-0.25 to +0.25	0.08	0.08	0.08	-	-	0.16	0.16	0.2	-	-
BN	-1 to +1	0.16	0.3	0.16	0.32	-	0.3	0.5	0.3	0.48	-
BR	0 to 2	0.16	0.3	0.16	0.6	0.48	0.3	0.5	0.3	0.68	0.72
BU	-5 to +5	0.2	0.4	0.2	4	4	0.4	0.8	0.4	5	6
CP	1 to 10	0.2	0.4	0.2	4	4	0.4	0.8	0.4	5	6
E4	2 to 50	3	9.5	3	16	16	6	13	6	18	24
E7	1 to 5	0.35	1	0.35	17.5	17.5	0.7	1.5	0.7	20	0.9
GP	1 to 20	0.7	2	0.7	3	3	1.5	3	1.5	3.6	4
J3	2 to 60	2	6.5	2	8.5	8.5	4.5	8.5	4	10	12

Flameproof models may be up to 2 times higher depending on the range. Should the differential be critical for specific applications, our engineers should be consulted prior to ordering.

Technical Specifications

ACCURACY

Set point repeatability $\pm 1\%$ of full scale at 20°C ambient.

Scale accuracy $\pm 3\%$ of full scale.

AMBIENT TEMPERATURE RANGE

All models are suitable for operating within a range of ambient temperature from -25 to +60°C (-13 to +140°F).

MAXIMUM PROCESS TEMPERATURE

Subject to appropriate installation practice, the component parts will withstand up to +60°C (+140°F). For higher temperatures refer to Models 301 and S31.

ELECTRICAL CONNECTIONS

Terminal Block

Cable entry is to a non-pinching block made of a non-hygroscopic thermosetting plastic, suitable for cables up to 2.5mm²/14AWG.

Earthing/Grounding

An earthing stud is provided inside all weatherproof enclosures, adjacent to the entry. External earthing is standard on flameproof versions.

'W' and 'N' Safety Note

If a metal cable gland is site fitted it must either be earthed locally or an earth/gland plate must be used to connect the body of the gland at the enclosure earthing point. Earth/gland plates can be provided either factory fitted or in kit form for site assembly. Ask for details.

Dielectric Strength

The electrical assembly is capable of withstanding *2kV between live parts and earth/ground and 500V between open contacts.

*1.2kV for micro switch Codes H2, H3, H4 and H6. Refer to Table 6.

Electrical Entry

Standard options are listed in Table 3. Other threads can be accommodated by adaptors. Dual entry available on some enclosures.

OPTIONAL EXTRAS

Mounting

Position/Location/Installation

Vertical as shown, in DIMENSIONS, taking care to avoid siting in locations that transmit excessive shock or vibration. For further advice contact our engineers.

Approvals

CENELEC / ATEX II 2 G D (Enclosure Codes H and K and all models).
 Certified to CENELEC EN50 014, EExd 11C T6 (-60 to +40°C), EExd IIC T4 (-60 to +80°C) EN50 018, EN50 021-1-1 (DUST), EN5028-1-1 (DUST)
 For use in Zone 1 hazardous areas. Category 2.

Certificate number BASOATEX2426X



IECEx APPROVAL for use in Zone 1 hazardous areas
 Exd IIC certified to IEC 60079-0 and IEC60079-1
 Cert No. IECExITS04 0006X

Dimensions

All dimensions mm (inches)

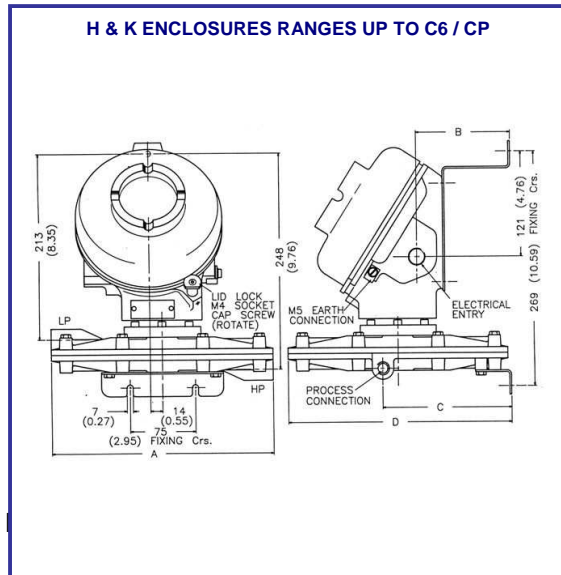
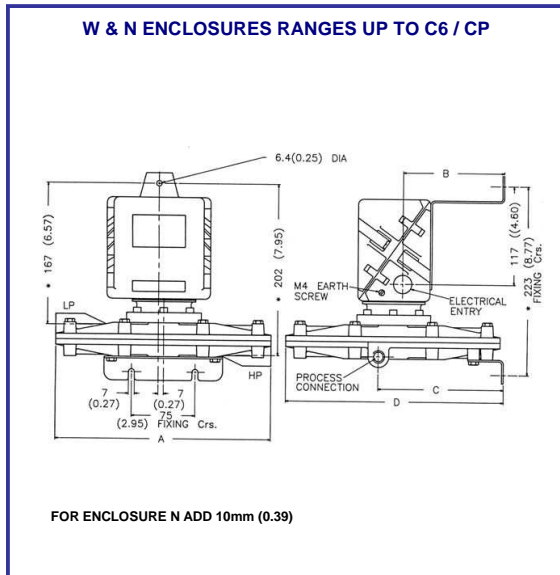

Dimensions

All dimensions mm (inches)

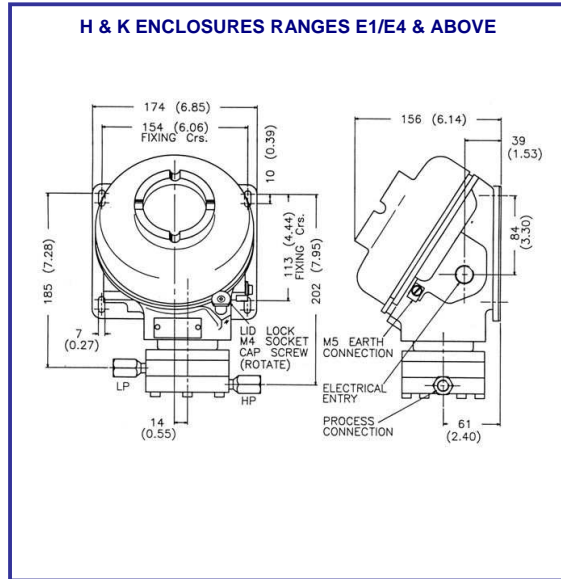
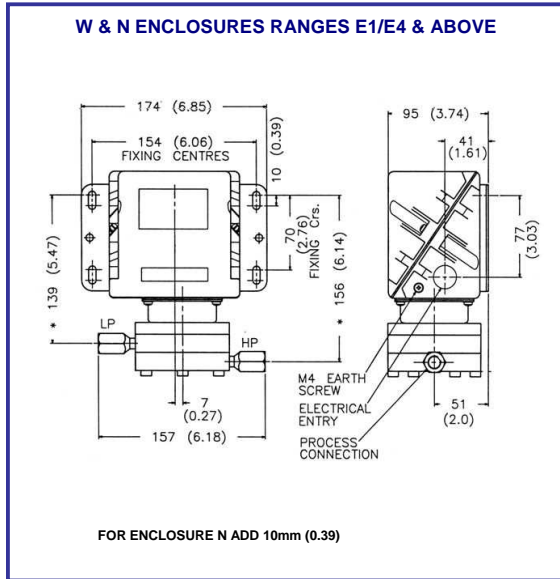

Range	Enclosure	A	B	C	D
B2 / B6	W & N	255 (10.0")	121 (4.75")	149 (5.86")	259 (10.19")
	H & K	255 (10.0")	109 (4.29")	149 (5.86")	259 (10.19")
B3/BN/B5/BR/BC /BU/C6/CP	W & N	160 (6.29")	77 (3.03")	104 (4.09")	164 (6.45")
	H & K	160 (6.29")	65 (2.55")	104 (4.09")	164 (6.45")

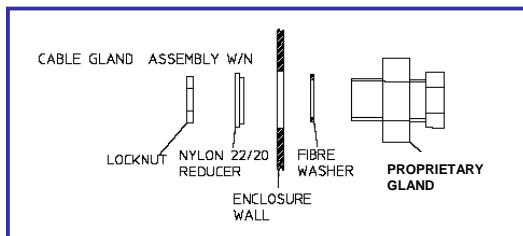

In the interest of development and improvement Delta Controls Ltd, reserves the right to amend, without notice, details contained in this publication. Delta Controls Ltd will accept no legal liability for any errors, omissions or amendments.



Delta Controls Limited

Island Farm Avenue, West Molesey, Surrey KT8 2UZ, UK.

T+44 (0)20 8939 3500 F+44 (0)20 8783 1163 [E sales@delta-controls.com](mailto:sales@delta-controls.com) [W www.delta-controls.com](http://www.delta-controls.com)

