

Performance Bourdon Operated Pressure Switches **230 Series**

231 / 2 / 3 / 4
Issue I

- Precision stainless steel mechanism for arduous atmospheres and high humidity.
- Ranges available up to 600 bar (8500 psi).
- Weatherproof and Flameproof models EEx d IIC - ATEX.
- Models for fixed switching differential, adjustable differential and HI-LO operation
- Safety vented design as standard.
- Hermetically sealed microswitch option.



Performance **characteristics**

Enclosure

- IP66 Protection

Wetted parts options

- Bourdon tube and process connection 316 Stainless Steel welded fabrication.
- Nickel Alloy (Monel) bourdon tube and connection suitable for NACE MR-01-75.

Standard Electrical ratings – Refer to Table 6

- 5 Amps – General purpose, environmentally sealed and hermetically sealed.
- 1 Amp with gold contacts.

Process connection

- Rc ¼ (BSP), ¼ NPT Internal, ½ NPT Internal & ½ NPT External.

Unit weight

- Between 3.1kg – 9.4kg (6.8lb – 20.7lb)

Accuracy

- Set point repeatability $\pm 1\%$ of span at 20 °C / 68 °F ambient.
- Scale accuracy $\pm 3\%$ of full scale.

Product **applications**

The 230 is suitable for a wide range of applications in many industry sectors:

- Oil & Gas
- Chemical
- Petrochemical
- Refining
- Power
- Food Industry

The choice of models available ensures that the 230 is suitable for use in:

- Corrosive atmospheres
- Resistant to chemical attack

How can we **help you?**

Delta Controls' range of reliable pressure and temperature measurement instruments can be customised to meet individual requirements. For technical advice or to discuss your application please contact us on +44 (0) 20 8939 3500

Enclosure

FINISH



All enclosures except Type A are finished in light grey epoxy resin paint. Special finishes to order.

INTRINSIC SAFETY

Because of the low voltages and currency of I.S. circuits, we recommend using gold and/or sealed contacts.

Temperatures in Table 1 refer to limitations for certified enclosures. See **TECHNICAL DATA**.

TABLE 1

	Code	
WEATHERPROOF ENCLOSURES		
General Purpose The basic enclosure is pressure die-cast in zinc alloy, offering weather protection not less than NEMA 4 + 13/IP66.	W	
For Aggressive Atmospheres Investment cast enclosure in austenitic stainless steel with weather protection not less than NEMA 4X + 13/IP66.	A	
FLAMEPROOF ENCLOSURES CATEGORY 2 (ZONE 1)		
ATEX EExd IIC T6 (-60 to + 40°C), T4 (-60 to +80°C) Gravity die-cast enclosure in aluminium-silicon alloy, certified to CENELEC EN50 014 and EN50 018. Suitable for outdoor use, IP66 / NEMA 4. <div style="float: right; text-align: center;">  </div>	H	
IECEX Exd IIC certified to IEC 60079-0 and IEC60079-1		
ATEX EExd IIC T6 (-60 to + 40°C), T4 (-60 to +80°C) As Code H, but sand cast in high quality grey iron. <div style="float: right; text-align: center;">  </div>	K	
IECEX Exd IIC certified to IEC 60079-0 and IEC 60079-1		
EExn ENCLOSURES CATEGORY 3 (ZONE 2)		
ATEX - Type of Protection EExn II T6 (-20 to +40°C) As code 'W' but EExn to EN50021. Weatherproof to NEMA 4/IP66. <div style="float: right; text-align: center;">  </div>	N	
Limited switching facility (see table 6) As 'N' but with investment cast enclosure in austenitic stainless steel as 'A'.		O

Models

TABLE 2

	Code
Fixed Switching Differential. See table 10A and 10D. Basic model giving close, fixed switching differential using proprietary microswitch operated by high integrity stainless steel mechanism. Set point field adjustable over full range against calibrated scale. SPDT & DPDT options available.	231
Adjustable Switching Differential. (Limited Span). See Table 10B & 10E. Achieved by special micro switch with built in adjuster, SPDT only. Not available with enclosure code N.	232
Adjustable Switching Differential (Wide Span). See table 10B & 10E. Separate control of set and reset points with individual setting points on calibrated scale.	233
HI-LO Switching (Adjustable Gap). See Tables 10C & 10F Two individual set points, with independent adjustment against scale.	234

Electrical Entry

Adaptors are available for other popular thread sizes.

Enclosures 'W' and 'N'

Standard option code 1 (22mm dia) is provided with a nylon 22/20 reducer and fibre washer suitable for a standard M20 cable gland and back nut. Option code 0 elbow adaptor is factory fitted. Adapter kits may also be provided retrospectively to fit at site if required. Ask for details.

'W' and 'N' SAFETY NOTE

If a metal cable gland is site fitted it must either be earthed locally or an earth/gland plate must be used to connect the body of the gland at the enclosure earthing point. Earth/gland plates can be provided either factory fitted or in kit form for site assembly. Ask for details.

TABLE 3

	Code
Enclosure W & N: Clearance for 20mm (3/4) in outside dia conduit.	1
Enclosures H, K & A: M20 x 1.5 ISO thread.	0
Enclosures H & K: M20 x 1.5 ISO thread, dual entry.	5
Enclosures H & K: 3/4-NPT INT.	3
Enclosures H & K: 3/4-NPT INT. dual entry	6
Enclosure W: M20 x 1.5 elbow adaptor.	0
Enclosure N: M20 x 1.5 straight adaptor (Approved).	0

Material of Wetted Parts

TABLE 4

	Code
Bourdon tube and process connection of 316 stainless steel welded fabrication.	2
Nickel alloy (Monel) bourdon tube and connection*. For wetted parts required to conform with Sour Gas and Sour Crude applications as laid down in NACE standard MR-01-75*.	M

*See Table 5 for availability.

Setting Ranges

TABLE 5

P_{max} = maximum working pressure

NOTE: Range codes shown are for bar/psi units only. Code will differ for other units.

For ranges and models requiring Monel wetted parts not shown in Table 5, refer to Chemical Seals in **TECHNICAL DATA**.

P_{max}	Range bar/PSI	AVAILABILITY			Code
		MODELS			
		ST ST	Monel	ST ST	
		231		232 233 234	
125 1800	0 to 100 0 to 1500	✓	-	✓	U0 UB
184 2670	0 to 160 0 to 2000	✓	-	✓	U5 UF
287 4160	0 to 250 0 to 3500	✓	-	✓	V5 V2
460 6670	0 to 400 0 to 5800	✓	✓	✓	W6 W2
690 10,000	0 to 600 0 to 8500	✓	✓	✓	Y3 YB

Switching Options

TABLE 6

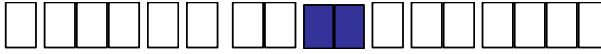

A much wider variety of switching options can be engineered to customers' special requirements for models 231 and 234 pressure switches, including heavy DC, manual latching, pneumatic output etc. Please consult our engineers for further information. On models 232 and 233, only the switching options specified can be supplied.

Model 231									
UL/CSA Rating (RESISTIVE) §SEE NOTE	IEC 947-5-1/EN 60947-5-1 Rating							Contact	Code
	Designation & Utilization Category	Rated operational current I _e (A) at rated operational voltage U _e	U _i	U _{imp}	VA Rating				
					Make	Break			
5 Amps @ 110/250V AC Light Duty for AC only	AC14 D300	0.6/0.3A @ 120/240V AC	250V	0.8kV	432	72	SPDT DPDT	00 01	
	DC13 R300	0.22/0.1A @ 125/250V DC			28	28			
5 Amps @ 110/250V AC & 2 Amps @ 30V DC General purpose precision	AC14 D300	0.6/0.3A @ 120/240V AC	250V	0.8kV	432	72	SPDT DPDT	02 03	
	DC13 R300	0.22/0.1A @ 125/250V DC			28	28			
1 Amp @ 125V AC & §100mA @ 30V DC gold alloy contacts for low voltage switching	1 A @ 125 VAC RESISTIVE (IEC 1058-1/EN 61058-1)							SPDT DPDT	04 05
§ 5 Amps @ 110/250V AC & 5 Amps @ 30V DC Environmentally sealed.	AC14 D300	0.6/0.3A @ 120/240V AC	250V	0.5kV	432	72	SPDT* DPDT*	08 09	
	DC13 R300	0.22/0.1A @ 125/250V DC			28	28			
§ 1 Amp @ 30V AC & 30V DC Environmentally sealed with gold contacts	AC14 E150	0.3A @ 120V AC	125V	0.5kV	216	36	SPDT* DPDT*	0G 0H	
5 Amps @ 250V AC and 2 Amps @ 30V DC Hermetically sealed. Gold plated silver contacts.	AC14 D300 DC13 R300	0.6/0.3A @ 120/240V AC 0.22/0.1A @ 125/250V DC	250V	0.5kV	432 28	72 28	SPDT* DPDT*	H2 H3†, H6‡	
† 2 Single pole, double throw, simultaneous falling under pressure ‡ 2 Single pole, double throw, simultaneous rising under pressure.									
Model 232 (Cannot be supplied with enclosure Code N)									
5 Amps @ 110/250V AC Light Duty for AC only adjustable	AC14 D300	0.6/0.3A @ 120/240V AC	250V	0.8kV	432	72	SPDT	OC	
5 Amps @ 110/250V AC and 2 Amps @ 30V DC Adjustable	AC14 D300 DC13 R300	0.6/0.3A @ 120/240V AC 0.22/0.1A @ 125/250V DC	250V	0.8kV	432 28	72 28	SPDT	OD	
Model 233									
5 Amps @ 110/250V AC & 2 Amps @ 30V DC General purpose precision	AC14 D300 DC13 R300	0.6/0.3A @ 120/240V AC 0.22/0.1A @ 125/250V DC	250V	0.8kV	432	72	SPDT	02	
Model 234									
5 Amps @ 110/250V AC Light Duty for AC only	AC14 D300 DC13 R300	0.6/0.3A @ 120/240V AC 0.22/0.1A @ 125/250V DC	250V	0.8kV	432 28	72 28	SPDT	20	
5 Amps @ 110/250V AC & 2 Amps @ 30V DC General purpose precision	AC14 D300 DC13 R300	0.6/0.3A @ 120/240V AC 0.22/0.1A @ 125/250V DC	250V	0.8kV	432 28	72 28	SPDT	22	
1 Amp @ 125V AC & §100mA @ 30V DC gold alloy contacts for low voltage switching	1 A @ 125 VAC RESISTIVE (IEC 1058-1/EN 61058-1)							SPDT	24
§ 5 Amps @ 110/250V AC & 5 Amps @ 30V DC Environmentally sealed.	AC14 D300	0.6/0.3A @ 120/240V AC	250V	0.5kV	432	72	SPDT*	28	
	DC13 R300	0.22/0.1A @ 125/250V DC			28	28			
§ 1 Amp @ 30V AC & 30V DC Environmentally sealed with gold contacts	AC14 E150	0.3A @ 120V AC	125V	0.5kV	216	36	SPDT*	2G	
5 Amps @ 250V AC and 2 Amps @ 30V DC Hermetically sealed. Gold plated silver contacts.	AC14 D300 DC13 R300	0.6/0.3A @ 120/240V AC 0.22/0.1A @ 125/250V DC	250V	0.5kV	432 28	72 28	SPDT*	H4	
<p>The electrical rating is dependent on the microswitch fitted to the instrument. The electrical rating defined by each approval that the microswitch complies with is shown on the product nameplate, ie UL/CSA, or IEC. It should be noted that the instrument must be used within the electrical rating specified from the approval required. This table lists the actual IEC ratings against the Designation & Utilization Category marked on the nameplates. In the absence of any verification by UL/CSA the microswitch § manufacturer's rating is stated in italics and bold. If in doubt seek guidance from the factory.</p> <p>NOTE: For low energy circuits e.g. 30V and up to 100mA, we recommend using gold alloy contact switches. U_i = rated insulation voltage U_{imp} = rated impulse withstand voltage across contacts.</p> <p>*Suitable for use with EExn Enclosures (Code N)</p>									

Process Connection

Other thread specifications and sizes are available without using adaptors.

Adaptors are available for applications where their use is permitted.

TABLE 7

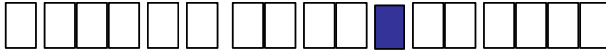

	Code
Rc 1/4 (1/4 BSP tr INT) to ISO 7/1	A
1/4 – 18NPT INTERNAL	F
1/2 – 14NPT INTERNAL	H
1/2 – 14NPT EXTERNAL	J

Options and Treatments

TABLE 8



	Code
Tropicalisation High humidity environment	01
Marine and Offshore Saline atmosphere or salt spray	02
Ammonia Process (wetted) parts and construction suitable for atmospheric ammonia.	03
Oxygen Service 2: Process (wetted) parts are cleaned for oxygen.	04
Oxygen Service 3: Process and non-process parts are cleaned for use with oxygen.	05
Stainless Steel Pipe Mounting Bracket Permits local 2" pipe work to be utilised for mounting the instrument.	10
Tagging - Variety of tagging methods are available	APPLY FOR DETAILS
Applies when – no option is required and selection is made from special engineering.	00

Special Engineering

TABLE 9



FEATURE	Code
Please consult Delta sales engineering for special requirements.	

Performance Data

TABLE 10

Bar Units (SI)

GAP= The difference between rising (HI) and falling (LO) in bar.

FIXED SWITCHING DIFFERENTIAL												
Model 231		BAR UNITS							TABLE 10A			
Code	Range	SPDT Options					DPDT Options					
		00	02	04	08 / 0G	H2	01	03	05	09 / 0H	H3 / H6	
U0	0 to 100	1.2	2.5	1.2	2	3.6	2.4	2.4	2.4	3	3.6	
U5	0 to 160	2	6	2	4	6	4	6	4	6	8	
V5	0 to 250	3	9	3	10	9	6	12	6	15	12	
W6	0 to 400	8	24	8	20	24	16	24	16	30	32	
Y3	0 to 600	12	36	12	60	36	24	30	24	90	50	

ADJUSTABLE SWITCHING DIFFERENTIAL									
Model 232 & 233		BAR UNITS				TABLE 10B			
Code	Adjustable Range	MODEL 232				MODEL 233			
		SPDT Only				SPDT Options			
		0C		0D		02			
		From	To	From	To	From	To		
U0	0 to 100	2	5	4	12	18	100		
U5	0 to 160	3.2	8	6.4	19	35	160		
V5	0 to 250	6	15	12	36	54	250		
W6	0 to 400	12	30	24	72	100	400		
Y3	0 to 600	18	45	36	108	150	600		

HI/LO SWITCHING - GAP = THE DIFFERENCE BETWEEN RISING (HI) AND FALLING (LO) IN bar																
Model 234		BAR UNITS										TABLE 10C				
Code	Range	20			22			24			28 / 2G			H4		
		Diff	Gap		Diff	Gap		Diff	Gap		Diff	Gap		Diff	Gap	
			Min	Max		Min	Max		Min	Max		Min	Max		Min	Max
U0	0 to 100	1.2	11	100	3.6	13	100	1.2	11	100	6	16	100	6	16	100
U5	0 to 160	2	25	160	8	28	160	2	25	160	10	33	160	10	33	160
V5	0 to 250	3	38	250	10.5	44	250	3	38	250	15	53	250	15	53	250
W6	0 to 400	8	80	400	24	96	400	8	80	400	40	120	400	40	120	400
Y3	0 to 600	12	100	600	36	124	600	12	100	600	60	160	600	60	160	600

PSI Units

Due to manufacturing tolerances, the figures quotes in these tables are for guidance only. Should the differential be critical for specific applications, our engineers should be consulted prior to ordering.

FIXED SWITCHING DIFFERENTIAL												
Model 231		PSI UNITS							TABLE 10D			
Code	Range	SPDT Options					DPDT Options					
		00	02	04	08 / 0G	H2	01	03	05	09 / 0H	H3 / H6	
UB	0 to 1500	18	36	18	29	52	35	35	35	44	52	
UF	0 to 2000	29	87	29	58	87	58	87	58	87	116	
V2	0 to 3500	44	131	44	145	130	87	174	87	218	174	
W2	0 to 6000	116	348	116	290	348	232	348	232	435	464	
YB	0 to 8500	174	522	174	870	508	348	435	348	1305	725	

ADJUSTABLE SWITCHING DIFFERENTIAL									
Model 232 & 233		PSI UNITS				TABLE 10E			
Code	Adjustable Range	MODEL 232				MODEL 233			
		SPDT Only				SPDT Options			
		0C		0D		02			
		From	To	From	To	From	To		
UB	0 to 1500	29	73	58	174	261	1500		
UF	0 to 2000	47	116	93	276	500	2000		
V2	0 to 3500	87	218	174	522	780	3500		
W2	0 to 6000	174	435	328	1044	1450	6000		
YB	0 to 8500	261	653	522	1566	2176	8500		

HI/LO SWITCHING - GAP = THE DIFFERENCE BETWEEN RISING (HI) AND FALLING (LO) IN psi																
Model 234		PSI UNITS										TABLE 10F				
Code	Range	20			22			24			28 / 2G			H4		
		Diff	Gap		Diff	Gap		Diff	Gap		Diff	Gap		Diff	Gap	
			Min	Max		Min	Max		Min	Max		Min	Max		Min	Max
UB	0 to 1500	18	160	1500	52	189	1500	18	160	1500	87	232	1500	87	232	1500
UF	0 to 2000	29	363	2000	116	406	2000	29	363	2000	145	480	2000	145	480	2000
V2	0 to 3500	44	551	3500	152	638	3500	44	551	3500	770	770	3500	770	770	3500
W2	0 to 6000	116	1160	6000	348	1393	6000	116	1160	6000	1740	1740	6000	1740	1740	6000
YB	0 to 8500	174	1450	8500	522	1798	8500	174	1450	8500	2320	2320	8500	2320	2320	8500

Technical Specifications

ACCURACY

Set point repeatability $\pm 1\%$ of full scale at 20°C ambient.
Scale accuracy $\pm 3\%$ of full scale.

AMBIENT TEMPERATURE RANGE

All models are suitable for operating within a range of ambient temperature from -25 to +60°C (-13 to +140°F). Special build available for temperatures down to -60°C (-76°F)

MAXIMUM PROCESS TEMPERATURE

Subject to appropriate installation practice, the component parts will withstand up to +120°C (+248°F). For higher temperatures refer to **SPECIAL ENGINEERING**.

ELECTRICAL CONNECTIONS

Terminal Block

Cable entry is to a non-pinching block made of a non-hygroscopic thermosetting plastic, suitable for cables up to 2.5mm²/14AWG.

Earthing/Grounding

An earthing stud is provided inside all weatherproof enclosures, adjacent to the entry. External earthing is standard on flameproof versions. Safety note see Table 3

Dielectric Strength

The electrical assembly is capable of withstanding *2kV between live parts and earth/ground and 500V between open contacts.

*1.2kV for micro switch Codes H2, H3, H4 and H6. Refer to Table 6.

Electrical Entry

Standard options are listed in Table 3. Other threads can be accommodated by adaptors. Dual entry available on some enclosures.

OPTIONAL EXTRAS

Chemical Seals

Chemical seals of our own or proprietary manufacture can be fitted when required.

Mounting

Position/Location/Installation

Vertical as shown, in DIMENSIONS, taking care to avoid siting in locations that transmit excessive shock or vibration. For further advice contact our engineers.

Pollution degree (EN60947-5-1)

All products are suitable for use in pollution degree 3. For extreme conditions where condensation may readily form, then sealed contacts should be used. See Table 6 codes 08/09/28/29, 0G/0H/2G/2H, H2/H3/H4/H6.

Electrical Isolation – These products are not suitable for electrical isolation. Always isolate circuit separately to carry out any electrical work.

Unit Weights

ENCLOSURES	Approx.
'W' & 'N'	3.1kg/5.8lb
'A' & 'O'	3.9kg/8.6lb
'H'	4.6kg/10.2lb
'K'	9.4kg/20.7lb

Approvals

INTRINSIC SAFETY

Because of the low voltages and currents of intrinsically safe circuits, we recommend using gold contacts. Refer to Table 6.

CENELEC/ATEX II 2 G D

Certified to CENELEC EN50 014 and EN50 018.

For use in Zone 1 hazardous areas EEx d IIC T6 (-60° to +40°C)
T4 (-60° to +80°C)



Enclosure Codes H and K and all models (see Table 1)

Certificate number BAS01ATEX2426X

IEC EX APPROVAL for use in Zone 1 hazardous areas

Exd IIC certified to IEC 60079-0 and IEC 60079-1

Cert No. IECExITS04 0006X

Dimensions

All dimensions mm (Inches)

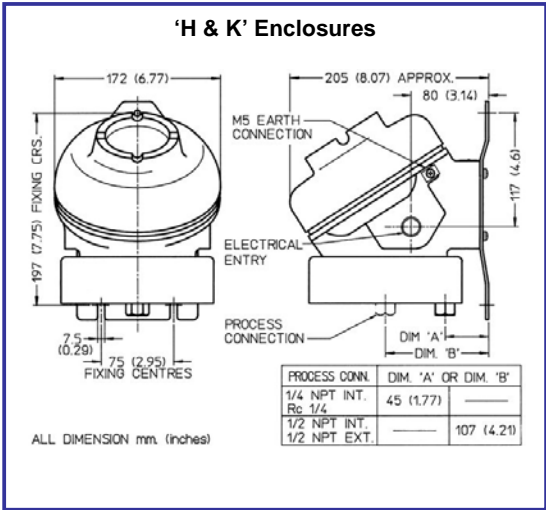
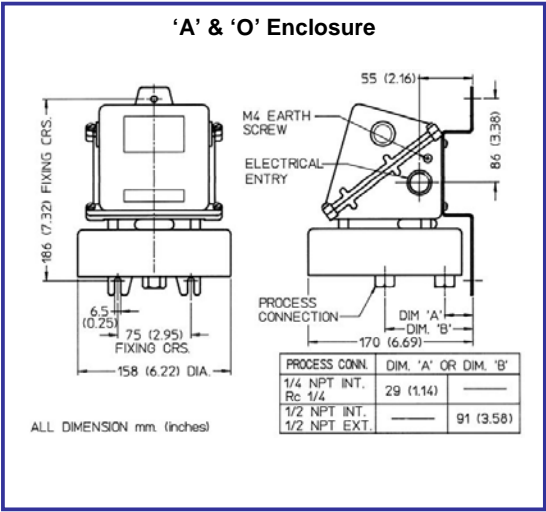
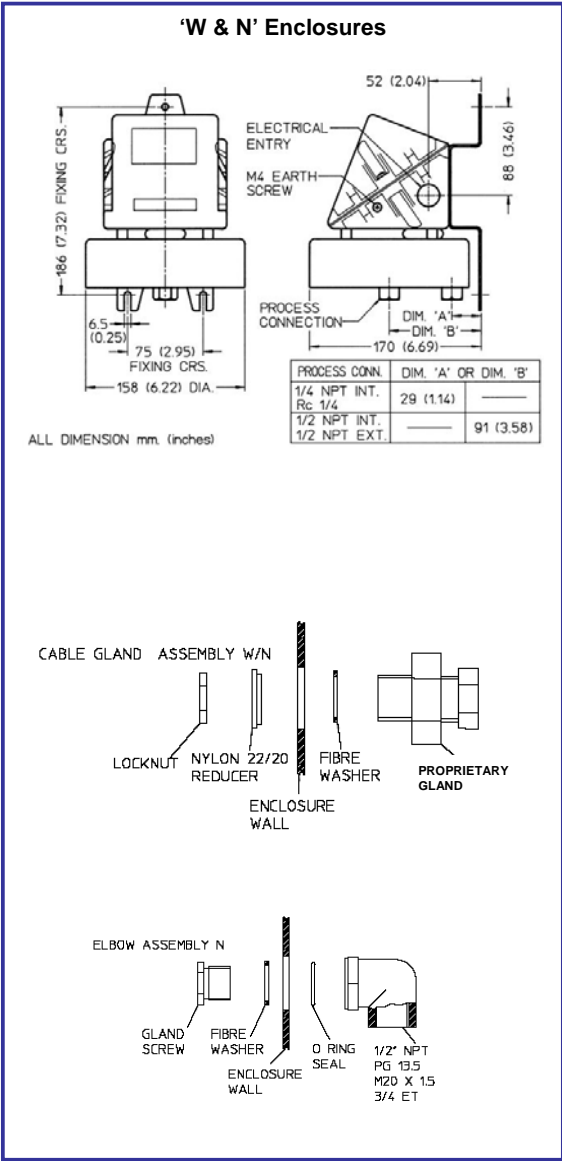

In the interest of development and improvement Delta Controls Ltd, reserves the right to amend, without notice, details contained in this publication. Delta Controls Ltd will accept no legal liability for any errors, omissions or amendments.



Delta Controls Limited

Island Farm Avenue, West Molesey, Surrey KT8 2UZ, UK.

T+44 (0)20 8939 3500 F+44 (0)20 8783 1163 [E sales@delta-controls.com](mailto:sales@delta-controls.com) [W www.delta-controls.com](http://www.delta-controls.com)



FM00720