

GENERAL

The unit is manufactured, checked and supplied in accordance with our published specification, and when installed and used in normal or prescribed applications, with the lid in place and within the parameters set for mechanical and electrical performance, will not cause danger or hazard to life or limb.

HEALTH AND SAFETY AT WORK ACT 1974 WARNINGS

1. THE USERS ATTENTION IS DRAWN TO THE FACT THAT, WHEN THE UNIT IS 'LIVE' WITH RESPECT TO ELECTRICAL OR PRESSURE SUPPLIES, A HAZARD MAY EXIST IF THE UNIT IS OPENED OR DISMANTLED.
2. UNITS MUST BE SELECTED AND INSTALLED BY SUITABLY TRAINED AND QUALIFIED PERSONNEL IN ACCORDANCE WITH APPROPRIATE CODES OF PRACTICE SO THAT THE POSSIBILITY OF FAILURE RESULTING IN INJURY OR DAMAGE CAUSED BY MISUSE OR MISAPPLICATION IS AVOIDED.

OPERATING PRINCIPLES

A diaphragm is used to sense the difference between two pressures applied to either side of the diaphragm. The force is opposed by a control spring, which, at the point of equilibrium permits movement of an operating rod that actuates a switch or switches.

INSTALLATION

The instruments are designed to be mounted to a wall or panel vertically as shown in figs 4, 5, 6, 7, 8, 9 using the backplates provided. However, mounting up to 45° from the vertical in any plane is acceptable, although a small calibration shift may occur. Select the mounting point so as to avoid excessive shock, vibration or temperature fluctuation. Instruments should be mounted to avoid excessive heat transfer from the process lines or adjacent plant. To avoid undue stresses being imparted to the instrument when wall / panel mounted, it is recommended that a short length of flexible line be installed between the instrument and process line.

If sudden changes of pressure (pulsations) are likely then we recommend that snubbers are fitted between the process line and switch.

Use a spanner to support the process connection when fitting the instrument. DO NOT OVERTIGHTEN. When fitting the instrument lid, make sure gaskets or 'O' rings are in good condition and fitted correctly.

WARNING: CHECK THE CONNECTION THREAD SIZE AND SPECIFICATION ON THE UNIT TO AVOID MIS-MATCHING WITH THE PROCESS CONNECTION ADAPTOR. SEE DIGIT 11 OF PRODUCT CODE.

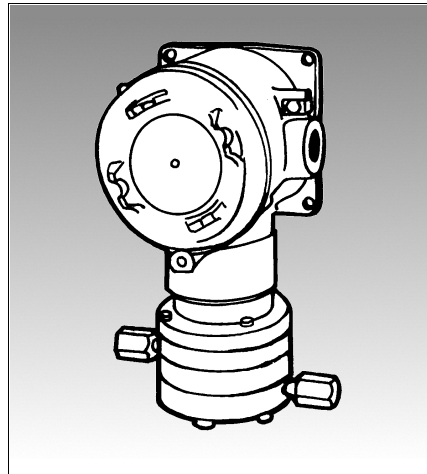

PRODUCT CODE

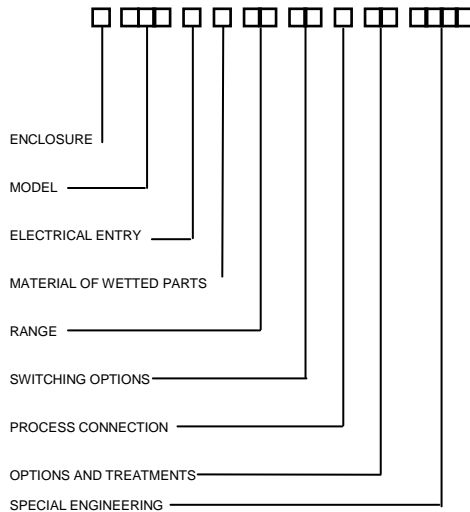

CERTIFIED ENCLOSURES

All series S30 pressure switches can be supplied with enclosures for use in hazardous areas to the following standards:

Zone 1 (Div 1) IEC 79-1

BS 5501: Parts 1 and 5: EN50 014 and EN50 018 CENELEC. Codes 'H' for aluminium EEx d IIC T6, and 'R' for stainless steel EExd IIC T6.

DIV 1 (NEC 500)

Class I Groups C and D, Class II Groups E, F and G. Codes 'T' for aluminium and 'U' for stainless steel.

The above-mentioned enclosures are suitable for outdoor use rated IP 66 / NEMA 4. Only operation, maintenance or repair procedures either contained herein or approved by Delta Controls may be used, to avoid rendering the equipment unsafe in operation and / or nullifying the Certification. NO MODIFICATIONS ARE PERMITTED.

Japanese Zone 1.

Same as CENELEC Zone 1 IEC 79 with additional label and alternative terminal arrangement. Code 'B' for aluminium IIC T6. Refer to appropriate Japanese standards for guidance on installation and use.

Electrical Adaptors

Use only certified adaptors for Zone 1/Div 1.

WARNING: IT IS A REQUIREMENT OF SAFETY THAT AT LEAST 5 FULL THREADS ARE ENGAGED BETWEEN THE ADAPTOR AND CONDUIT ENTRY.

References for Selection and Installation

BS 5345 Part 3 for Enclosure Codes H and R. BS 5501 Part 1 for Enclosure Codes H and R. BS 5490 IEC 529 IP RATING (Ingress Protection) NEC ARTICLE 500 for Enclosure Code T and U.

MAINTENANCE

Inspections should be carried out at quarterly to yearly intervals depending upon operating conditions.

Isolate the unit from process and power and remove the lid. Check all terminals for tightness. Check that cable tails are not fouled or chafed. Check for internal condensation. Rectify as necessary.

It is recommended that instruments used to provide an alarm are operated periodically to ensure they are functioning correctly.

If further maintenance is required seek advice from DELTA CONTROLS before attempting repair or replacement of parts.

CAUTION

Moving parts have been treated with a water repelling lubricant before leaving the factory. Occasional inspection and the application of a water repelling lubricant is recommended to ensure moving parts remain free under all conditions.

WARNING: DOES NOT APPLY TO OXYGEN SERVICE.

On enclosures H, R, T, U and B, remove the lid using an appropriate tool. If tight use edge of a spanner or a metal rod (fig 4A).

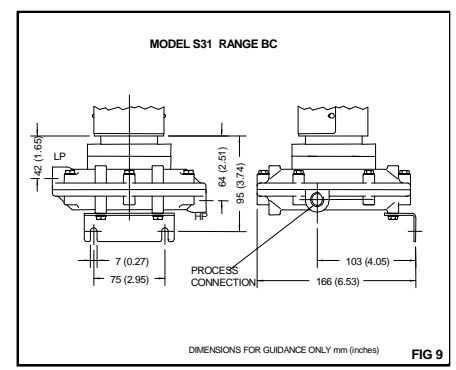
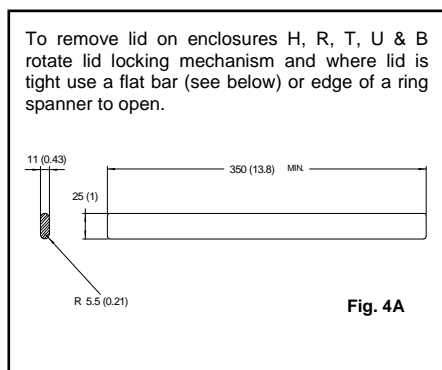
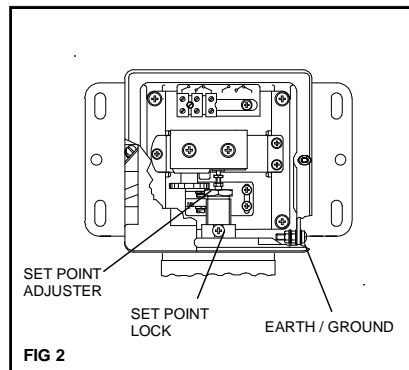
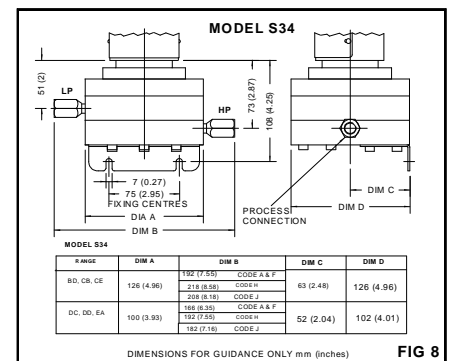
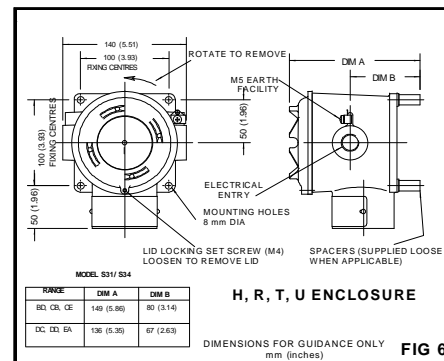
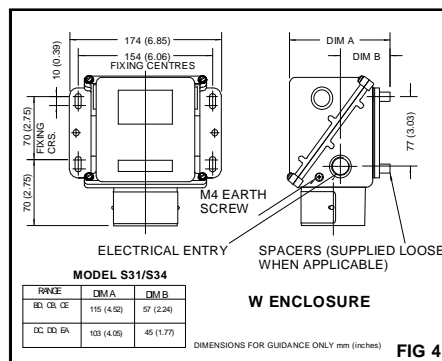
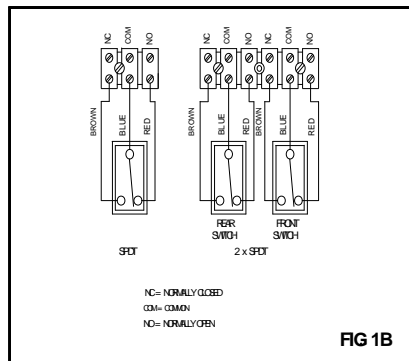
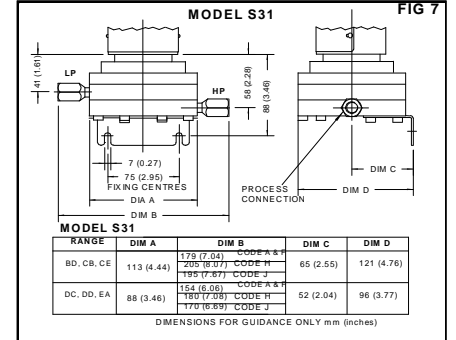
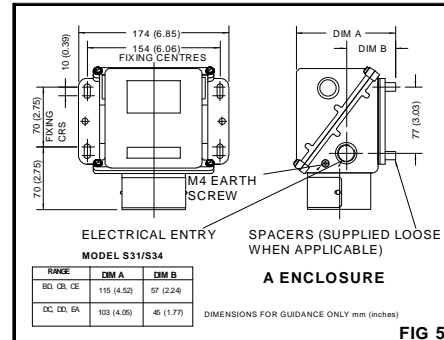
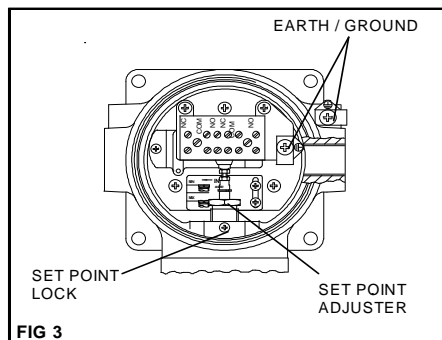
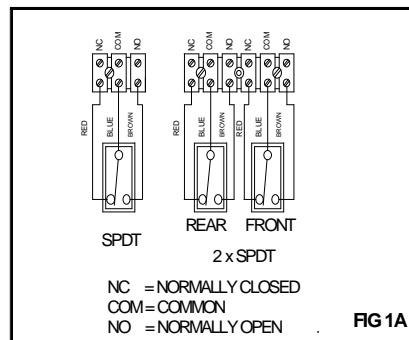

In the interest of development and improvement Delta Controls Ltd, reserve the right to amend without notice, details contained in this publication. No legal liability will be accepted by Delta Controls Ltd, for any errors, omissions or amendments.

YOUR TRUSTED PARTNER IN PROCESS INSTRUMENTATION

DELTA CONTROLS LIMITED, ISLAND FARM AVENUE, WEST MOLESEY, SURREY KT8 2UZ
T +44 (0) 208 939 3511 F +44 (0) 208 783 1163 E sales@delta-controls.com W www.delta-controls.com

CE Low Voltage Directive (LVD) – 2006/95/AC. Switch products with enclosure codes 'W' and 'A' supplied CE-marked must be installed and used in accordance with the main instructions and this addendum supplied with each product. Products rated lower than 50V ac and 75 V dc are outside the scope of the LVD, and therefore, do not require CE-marking under this directive. The LVD does not apply to products with enclosure codes 'H', 'K', 'R', 'M', 'N' for use in hazardous areas. Switch products with enclosure codes 'H', 'K', 'R', 'M', 'N', are covered by the Explosive Atmospheres Directive ATEX – 94/9/EC and when CE-marked will indicate compliance with this directive alone. The following directives do not apply to switch products manufactured by Delta Controls:
 Electromagnetic Compatibility EMC – 2004/08/EC
 Machinery Safety Directive MSD – 2006/42/EC

Pollution degree – all products are suitable for use in pollution degree 3. For extreme conditions where condensation may readily form, then sealed contacts should be used. See Table A codes 08/09, 0G/0H, H2/H3/H6.

Electrical isolation – These products are not suitable for electrical isolation. Always isolate circuit separately to carry out any electrical work.

WIRING ENCLOSURE 'W'

Cable Glands and adaptors – If enclosure 'W' is supplied with a through hole of 22 mm blanked with a blind grommet. Discard the grommet and fit a suitable proprietary brass or nylon M20 cable gland with thread length of 10 mm and locknut. Fit the nylon reducer provided to the inside and a fibre washer to the outside. See diagram 1.
 Alternately, the enclosure may be supplied from the factory with a threaded adaptor ready to accept the customer's gland or conduit system.

Alternatives:

- i) a metal or nylon adaptor may be used to accommodate other sizes of gland eg NPT, or conduit system. See diagram 2.
- ii) an elbow kit may be supplied to enable the entry to be rotated axially through 90° and radially through 360°. See diagram 3.

Earthing / grounding – The user must make suitable local earthing arrangements, if required, to ensure that metal glands are earthed.

An earthing point is provided inside the enclosure. If this is disturbed in any way it must be reassembled correctly to be an effective earth and prevent ingress. See diagram 4. When removing the lid slacken the M4 nut first and ensure it is re tightened whenever the lid is replaced. See diagram 4.1.

ENCLOSURE 'A'

Cable Glands and adaptors – Enclosure 'A' is supplied with an M20 x 1.5 tapped hole. Use a suitable stainless steel cable gland and sealing washer. Alternately the enclosure may be supplied with a threaded adaptor fitted at the factory ready to accept the customer's gland or conduit system. See diagram 5.

Earthing / grounding – Bonding between the enclosure and gland / adaptor will be achieved when both parts are screwed together. An earthing point is provided inside the enclosure. If this is disturbed in any way it must be reassembled correctly to be an effective earth and prevent ingress. See diagram 4.

EARTHING / GROUNDING OF PROCESS CONNECTION AND BACK PLATES – All the internal dead metal work is bonded to the enclosure earthing point. Due to requirements of sealing, the process connection and back plates may be isolated from the earthing point. Do not, therefore, rely on either for earthing, instead always use the earthing point provided. If required, the process connection and back plates may be bonded locally. Never use the process connection or inlet pipe for locally grounding welding equipment unless it is separately earth bonded.

TABLE A – MICROSWITCH RATINGS

SWITCH CODE	UL / CSA MICROSWITCH RATING (RESISTIVE) *SEE NOTE	IEC 947-5-1 / EN 60947-5-1 RATING						
		U _{imp}	U _i	RATING (I _e /U _e)	Designation & Utilisation Category	VA		
Make	Break							
00 & 01	5A @ 110 / 250 VAC	0.8kV	250 V	0.6/0.3A @ 120/240 VAC	AC 14 / D300	AC	432	72
				0.22/0.1A @ 125/250 VDC	DC 13 / R300	DC	28	28
02 & 03	5A @ 110 / 250 VAC 2A @ 30 VDC	0.8kV	250V	0.6/0.3A @ 120/240 VAC	AC 14 / D300	AC	432	72
				0.22/0.1A @ 125/250 VDC	DC 13 / R300	DC	28	28
04 & 05	1A @ 125 VAC *100mA @ 30 VDC	1A @ 125 VAC RESISTIVE (IEC 1058-1/EN 61058-1)						
08 & 09	*5A @ 110/250 VAC 5A @ 30 VDC	0.5kV	250V	0.6/0.3A @ 120/240 VAC	AC 14 / D300	AC	432	72
				0.22/0.1A @ 125/250 VDC	DC 13 / R300	DC	28	28
0G & 0H	*1A @ 30VAC & 30 VDC	0.5kV	125V	0.3A @ 120 VAC	AC 14 / E150	AC	216	36
0C	5A @ 110 / 250 VAC	0.8kV	250V	0.6/0.3A @ 120/240 VAC	AC 14 / D300	AC	432	72
0D	5A @ 110 / 250 VAC 2A @ 30 VDC	0.8kV	250V	0.6/0.3A @ 120/240 VAC	AC 14 / D300	AC	432	72
				0.22/0.1A @ 125/250 VDC	DC 13 / R300	DC	28	28
H2 & H3 & H6	5A @ 110 / 250 VAC 2A @ 30 VDC	0.5kV	250V	0.6/0.3A @ 120/240 VAC	AC 14 / D300	AC	432	72
				0.22/0.1A @ 125/250 VDC	DC 13 / R300	DC	28	28

The electrical rating is dependent on the microswitch fitted to the instrument. The electrical rating is defined by each approval that the microswitch complies with and is shown on the product nameplate, ie UL / CSA, or IEC. It should be noted that the switch must be used within the electrical rating specified from the approval you require. Table A lists the actual IEC ratings against the Designation & Utilisation Category marked on the nameplate. In the absence of any verification by UL / CSA the microswitch *manufacturer's rating is specified in **bold italics**. If in doubt, seek guidance from factory.

Declaration of Conformity



We: Delta Controls Ltd
 Island Farm Avenue
 West Molesey
 Surrey, UK
 KT8 2UZ

As the manufacturers of the apparatus listed, declare under our sole responsibility that the products listed below:

Pressure, Pressure Difference, Temperature & Flow switches series "W" or "A":
 201, 202, 203, 281, 204, 207, 208, 209, 231, 232, 233, 234, S21, S22, S24, GR2, GR4, VM2, VM4.
 301, 303, 304, 381, 384, 306, 386, 310, 316, S31, S34, GR3, GR6.
 721, 731, 771, 722, 732, 772, 723, 733, 773, 781, 734, 774, 741, 742, 743, 744, S71, GR7.
 131.

To which this declaration relates are in conformity with the following relevant standards or parts thereof:

- EN 60947-1 :1992 Low voltage switch gear and control-gear-general rules.
- EN 60947-5-1:1992 Low voltage switch gear and control-gear-control circuit devices and switching elements.
- EN 60529: 1991 Specification for classification of degrees of protection provided by enclosures.
- EN 60950:1992 Safety of information technology equipment including electrical business equipment: section 2.5.
- BS 6134:1991 Specification for pressure and vacuum switches.

And thereby conforms to the requirements of the Low Voltage Directive 73/23/EC amended by 93/68/EEC.

Signed:

R. Harrison
 Managing Director

Original dated 22nd June 2000
 Rev. B dated 12th August 2009