

GENERAL

The unit is manufactured, checked and supplied in accordance with our published specification, and when installed and used in normal or prescribed applications, with the lid in place and within the parameters set for mechanical and electrical performance, will not cause danger or hazard to life or limb.

HEALTH AND SAFETY AT WORK ACT 1974

WARNINGS

1. THE USERS ATTENTION IS DRAWN TO THE FACT THAT, WHEN THE UNIT IS 'LIVE' WITH RESPECT TO ELECTRICAL SUPPLIES, A HAZARD MAY EXIST IF THE UNIT IS OPENED OR DISMANTLED.

2. UNITS MUST BE SELECTED AND INSTALLED BY SUITABLY TRAINED AND QUALIFIED PERSONNEL IN ACCORDANCE WITH APPROPRIATE CODES OF PRACTICE SO THAT THE POSSIBILITY OF FAILURE RESULTING IN INJURY OR DAMAGE CAUSED BY MISUSE OR MISAPPLICATION IS AVOIDED.

CAUTIONS

It is advisable to avoid the condition where the ambient temperature is within $\pm 5^\circ\text{C}$ of the sensed temperature, as this will increase the switching differential.

OPERATING PRINCIPLES

A closed system containing an equilibrium of liquid and vapour of a suitable volatile chemical or gas is used to sense the process temperature. The pressure within the system is proportional to the applied temperature. This pressure is applied to the bellows which transmits a force, proportional to the temperature, to an operating beam. The beam is restrained by an adjustable spring. When the force on the beam overcomes the spring tension the beam moves and operates a switch or switches. On reduction of the applied temperature the force applied to the beam also falls, the beam is restored to its original position by the spring, and the switch resets.

INSTALLATION

The instruments are designed to be mounted vertically with the thermowell connection underneath. They can be mounted either direct to process (rigid stem) or to a wall or panel using the backplate provided. Select the mounting point so as to avoid excessive shock, vibration or temperature fluctuation. Instruments should be mounted to avoid excessive heat transfer from the process lines or adjacent plant.

Capillary version

Mount the sensing bulb so that the capillary end is above the bulb and the bulb is level with, or no more than 250 mm below the base of the instrument. The bulb is fitted with a sliding compression gland to accommodate different thermowells.

When fitting the instrument lid make sure gaskets and 'O' rings are in good condition and fitted correctly.

CAUTION: For the rigid stem version it is recommended that a portion of flexible conduit be used to prevent undue stresses being applied to the unit. For immersion lengths refer to figs 9, 10.

WARNING: CHECK THE CONNECTION THREAD SIZE AND SPECIFICATION TO AVOID MISMATCHING WITH THE PROCESS CONNECTION ADAPTOR. SEE DIGIT 11 OF THE PRODUCT CODE.

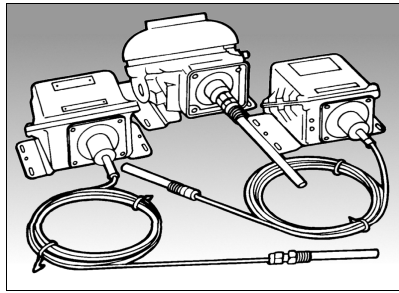

PRODUCT CODE

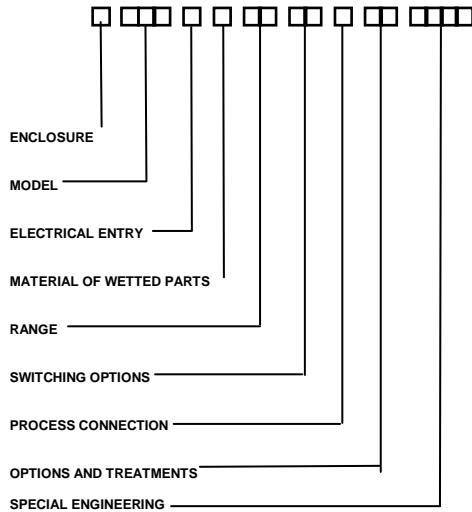

WIRING (Fig 1)

Wire in accordance with local and National codes. Use cables no larger than 2.5 mm^2 (14AWG). Deliver electrical connection through a suitable cable gland which will maintain the IP rating of the instrument. Insert bare wires fully into the terminal block and tighten securely. Keep wiring tails to a minimum and check that wires do not interfere with the operating mechanism. Use the earthing points provided.

CERTIFIED ENCLOSURES

All Series 700 Temperature Switches can be supplied with BASEEFA certified enclosures to the following standards:

Zone 1 (Div 1) IEC 60079-0 and IEC 60079-1
CENELEC EN50 014 and EN50 018 Codes 'H' for aluminium and 'K' for cast iron II 2GD Exd IIC T6

All enclosures are suitable for outdoor use and the majority of products are rated IP66. Refer to the product label and / or leaflet. Only operation, maintenance or repair procedures either contained herein or approved by Delta Controls may be used, to avoid rendering the equipment unsafe in operation and / or nullifying the Certification. NO MODIFICATIONS ARE PERMITTED.

Electrical Adaptors

Zone 1. Use only certified adaptors for Zone 1.

WARNING: IT IS A REQUIREMENT OF SAFETY THAT AT LEAST 5 FULL THREADS ARE ENGAGED BETWEEN THE ADAPTOR AND CONDUIT ENTRY. TAKE CARE TO SELECT AND INSTALL ADAPTORS THAT DO NOT REDUCE THE ENCLOSURE IP RATING.

Zone 2

Adaptors used must have equivalent IP rating to the enclosure and be impact resistant to 7Nm.

References for Selection and Installation

IEC 60079-14 for Enclosure Codes H and K
IEC 60079-14 for all Enclosure Codes (Intrinsic Safety)
EN 50021 for Enclosure Code N
IEC 50029 IP RATING (Ingress Protection)

MAINTENANCE

Inspections should be carried out at quarterly to yearly intervals depending upon operating conditions. Isolate the unit from process and power and remove the lid. Check all terminals for tightness. Check that cable tails are not fouled or chafed. Check for internal condensation. Rectify as necessary.

It is recommended that instruments used to provide an alarm are operated periodically to ensure they are functioning correctly. If further maintenance is required seek advice from DELTA CONTROLS before attempting repair or replacement of parts.

CAUTION

Moving parts have been treated with a water repelling lubricant before leaving the factory. Occasional inspection and the application of a water repelling lubricant is recommended to ensure moving parts remain free under all conditions.

WARNING: DOES NOT APPLY TO OXYGEN SERVICE

Zone 1 enclosures

Thread seal and contact surfaces must be lightly lubricated using a non-setting non-corrosive grease compatible with the nitrile lid seal. Do not use copper bearing grease on aluminium. Screw on lid hand tight making sure that mating surfaces of the lid and enclosure are in contact. Retighten the lid lock screw.

WARNING: IT IS A SAFETY REQUIREMENT THAT AT LEAST 5 FULL THREADS ARE ENGAGED WHEN THE UNIT IS IN OPERATION. NEVER OPERATE THE UNIT UNLESS THIS CONDITION IS MET. DO NOT USE GREASES OR LUBRICANTS NOT COMPATIBLE WITH THE ENVIRONMENT OR PROCESS.

Weatherproof Enclosure (W) and (N)

If lid gasket is dried out or damaged, replace with new greased gasket.

Stainless Steel Weatherproof Enclosure (A)

Check gasket. If damaged, replace.

On enclosures H, and K, remove the lid using an appropriate tool if tight, eg edge of a spanner or a metal rod (fig 1A).

OPERATION

Temperature switches are supplied calibrated against falling temperature unless otherwise specified. Set Point adjustment refers to falling temperature. Switching differential is the difference between the set point and the operating value on rising temperature. Before commencing adjustments or removing the lid, isolate the instrument from process and power.

Set Point Adjustment: Models 721, 722, 723, 731, 732, 733, 771, 772, 773 (Fig 2)

- Loosen the M3 hexagon head locking screw.
- Rotate the 20 mm A/F hexagon head adjuster knob to move the indicator along the calibrated scale. Rotate clockwise to increase the set point and counter clockwise to decrease the set point.
- Retighten the locking screw taking care not to over tighten.
- Replace the instrument lid (see maintenance).

Set Point Adjustment: Model 781, 734, 774 (Fig 3)

The model 781, 734, 774 provides 2 microswitches which can be set independently against individual scales using a special dual beam mechanism. This fulfils the need for HI LO switching. Adjust as follows:

- Loosen the rear M3 hexagon head locking screw.
- Rotate the rear adjuster screw to move the indicator on the right hand (LO) calibrated scale. Rotate clockwise to increase the set point and counter clockwise to decrease the set point.
- Retighten the locking screw.
- Loosen the front hexagon head locking screw.
- Rotate the front adjuster screw to move the indicator on the left hand (HI) calibrated scale. Rotate clockwise to increase the set point and counter clockwise to decrease the set point.
- Tighten the locking screw.
- Replace the instrument lid (see maintenance).

Switching Differential Adjustment: Model 722, 732, 772 (Fig 4)

- Rotate the knurled plastic wheel on the microswitch to adjust the switch differential. Rotate clockwise to increase the differential and counter clockwise to reduce the differential.
- Replace the instrument lid (see maintenance).

Switching Differential Adjustment: Model 723, 733, 773 (Fig 5)

- Rotate the secondary adjuster knob to move the secondary indicator along the 'arrow' scale. Rotate clockwise to increase the differential and counter clockwise to decrease the differential.
- Replace instrument lid (see maintenance).

Note: For accurate setting, a suitable temperature gauge should be used in conjunction with the above procedure. Do not attempt to set the switch outside the scale limits. Though the unit may be set anywhere within its operation range, for optimum performance, it is good practice to have a set point value between 25 % and 75 % of span.

REPLACEMENT PARTS

Use only factory authorised parts and procedures. The only parts normally recommended for site replacement are the microswitches. However, in some circumstances other spares kits are available. Apply for details quoting the serial number and full product code.

WARRANTIES - SEE CONDITIONS OF SALE

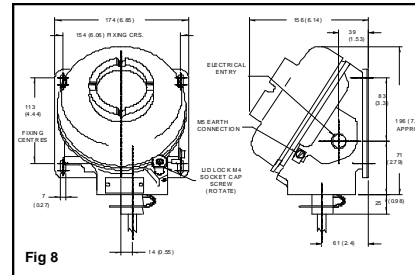
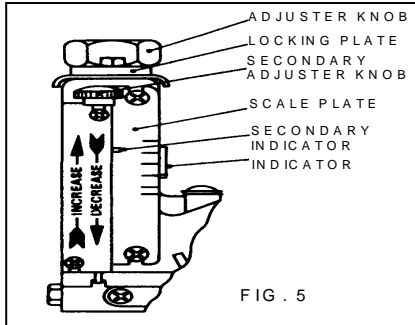
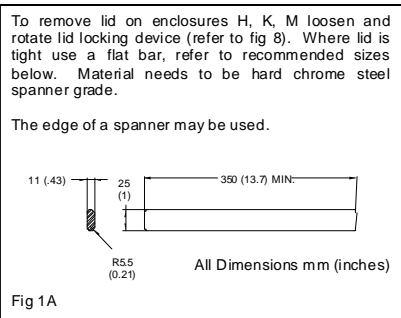
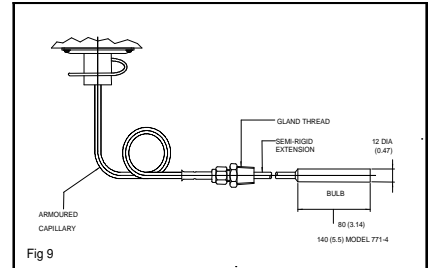
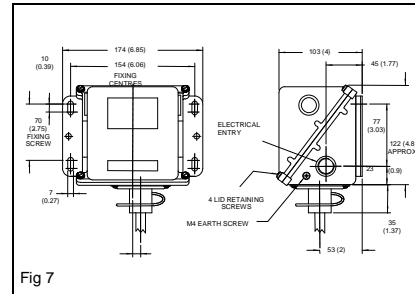
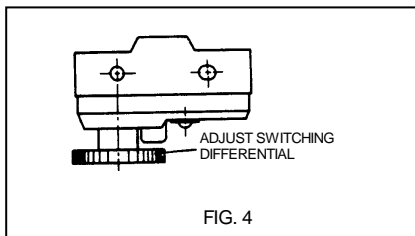
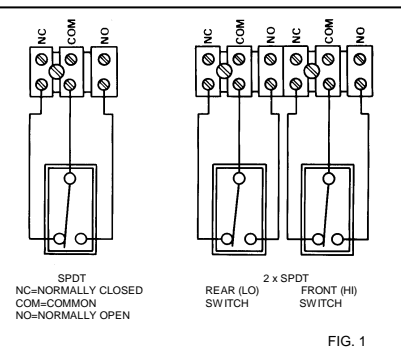

SENSING ELEMENT MODELS 721, 722, 723, 771, 772, 773, 774, 781

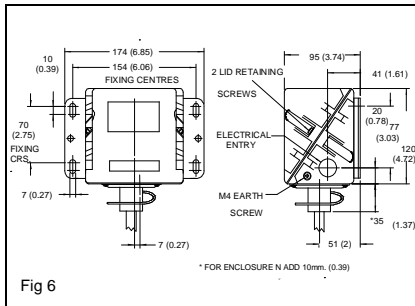
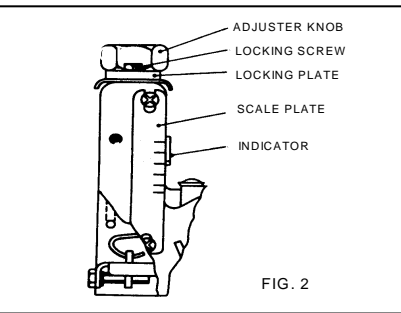
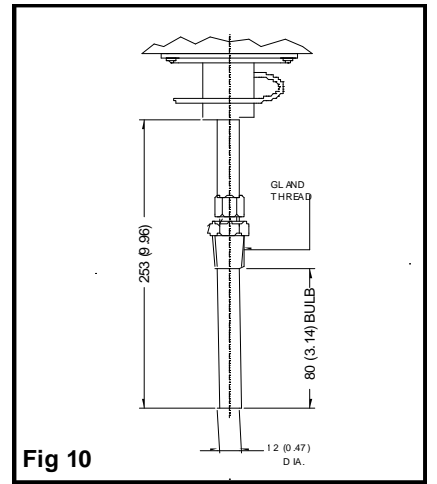

ENCLOSURES H, K, M

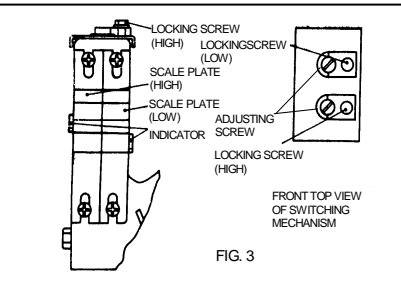

In the interest of development and improvement Delta Controls Ltd, reserve the right to amend without notice, details contained in this publication. No legal liability will be accepted by Delta Controls Ltd, for any errors, omissions or amendments.

YOUR TRUSTED PARTNER IN PROCESS INSTRUMENTATION

DELTA CONTROLS LIMITED, ISLAND FARM AVENUE, WEST MOLESEY, SURREY KT8 2UZ
T +44 (0) 208 939 3511 F +44 (0) 208 783 1163 E sales@delta-controls.com W www.delta-controls.com

Registered Office Registered in England No 5369683

Stock No: 002522/720

Zone 2 (UK Only)
BS 4683: Part 3, Enclosure Code 'N'. ExN IIT6.

CE Low Voltage Directive (LVD) – 2006/95/AC. Switch products with enclosure codes 'W' and 'A' supplied CE-marked must be installed and used in accordance with the main instructions and this addendum supplied with each product. Products rated lower than 50V ac and 75 V dc are outside the scope of the LVD, and therefore, do not require CE-marking under this directive. The LVD does not apply to products with enclosure codes 'H', 'K', 'R', 'M', 'N' for use in hazardous areas. Switch products with enclosure codes 'H', 'K', 'R', 'M', 'N', are covered by the Explosive Atmospheres Directive ATEX – 94/9/EC and when CE-marked will indicate compliance with this directive alone. The following directives do not apply to switch products manufactured by Delta Controls:
 Electromagnetic Compatibility EMC – 2004/108/EC
 Machinery Safety Directive MSD – 2006/42/EC

Pollution degree – all products are suitable for use in pollution degree 3. For extreme conditions where condensation may readily form, then sealed contacts should be used. See Table A codes 08/09, 0G/0H, H2/H3/H6.
Electrical isolation – These products are not suitable for electrical isolation. Always isolate circuit separately to carry out any electrical work.

WIRING ENCLOSURE 'W'

Cable Glands and adaptors – If enclosure 'W' is supplied with a through hole of 22 mm blanked with a blind grommet. Discard the grommet and fit a suitable proprietary brass or nylon M20 cable gland with thread length of 10 mm and locknut. Fit the nylon reducer provided to the inside and a fibre washer to the outside. See diagram 1. Alternately, the enclosure may be supplied from the factory with a threaded adaptor ready to accept the customer's gland or conduit system.

Alternatives:

- i) a metal or nylon adaptor may be used to accommodate other sizes of gland eg NPT, or conduit system. See diagram 2.
- ii) an elbow kit may be supplied to enable the entry to be rotated axially through 90° and radially through 360°. See diagram 3.

Earthing / grounding – The user must make suitable local earthing arrangements, if required, to ensure that metal glands are earthed.

An earthing point is provided inside the enclosure. If this is disturbed in any way it must be reassembled correctly to be an effective earth and prevent ingress. See diagram 4. When removing the lid slacken the M4 nut first and ensure it is re tightened whenever the lid is replaced. See diagram 4.1.

ENCLOSURE 'A'

Cable Glands and adaptors – Enclosure 'A' is supplied with an M20 x 1.5 tapped hole. Use a suitable stainless steel cable gland and sealing washer. Alternately the enclosure may be supplied with a threaded adaptor fitted at the factory ready to accept the customer's gland or conduit system. See diagram 5.

Earthing / grounding – Bonding between the enclosure and gland / adaptor will be achieved when both parts are screwed together. An earthing point is provided inside the enclosure. If this is disturbed in any way it must be reassembled correctly to be an effective earth and prevent ingress. See diagram 4.

EARTHING / GROUNDING OF PROCESS CONNECTION AND BACK PLATES – All the internal dead metal work is bonded to the enclosure earthing point. Due to requirements of sealing, the process connection and back plates may be isolated from the earthing point. Do not, therefore, rely on either for earthing, instead always use the earthing point provided. If required, the process connection and back plates may be bonded locally. Never use the process connection or inlet pipe for locally grounding welding equipment unless it is separately earth bonded.

TABLE A – MICROSWITCH RATINGS

SWITCH CODE	UL / CSA MICROSWITCH RATING (RESISTIVE) *SEE NOTE	IEC 947-5-1 / EN 60947-5-1 RATING				VA		
		U _{imp}	U _i	RATING (I _e /U _e)	Designation & Utilisation Category	Make	Break	
00 & 01	5A @ 110 / 250 VAC	0.8 kV	250 V	0.6/0.3A @ 120/240 VAC	AC 14 / D300	AC	432	72
				0.22/0.1A @ 125/250 VDC	DC 13 / R300	DC	28	28
02 & 03	5A @ 110 / 250 VAC	0.8 kV	250 V	0.6/0.3A @ 120/240 VAC	AC 14 / D300	AC	432	72
				0.22/0.1A @ 125/250 VDC	DC 13 / R300	DC	28	28
04 & 05	1A @ 125 VAC *100mA @ 30 VDC	1A @ 125 VAC RESISTIVE (IEC 1058-1/EN 61058-1)						
08 & 09	*5A @ 110/250 VAC 5A @ 30 VDC	0.5 kV	250V	0.6/0.3A @ 120/240 VAC	AC 14 / D300	A C	432	72
				0.22/0.1A @ 125/250 VDC	DC 13 / R300	DC	28	28
0G & 0H	*1A @ 30VAC & 30 VDC	0.5 kV	125V	0.3A @ 120 VAC	AC 14 / E150	AC	216	36
0C	5A @ 110 / 250 VAC	0.8 kV	250V	0.6/0.3A @ 120/240 VAC	AC 14 / D300	AC	432	72
0D	5A @ 110 / 250 VAC 2A @ 30 VDC	0.8 kV	250 V	0.6/0.3A @ 120/240 VAC	AC 14 / D300	AC	432	72
				0.22/0.1A @ 125/250 VDC	DC 13 / R300	DC	28	28
H2 & H3 & H6	5A @ 110 / 250 VAC 2A @ 30 VDC	0.5 kV	250 V	0.6/0.3A @ 120/240 VAC	AC 14 / D300	A C	432	72
				0.22/0.1A @ 125/250 VDC	DC 13 / R300	DC	28	28

The electrical rating is dependent on the microswitch fitted to the instrument. The electrical rating is defined by each approval that the microswitch complies with and is shown on the product nameplate, ie UL / CSA, or IEC. It should be noted that the switch must be used within the electrical rating specified from the approval you require. Table A lists the actual IEC ratings against the Designation & Utilisation Category marked on the nameplate. In the absence of any verification by UL / CSA the microswitch *manufacturer's rating is specified in **bold italics**. If in doubt, seek guidance from factory.

Declaration of Conformity



We: Delta Controls Ltd
 Island Farm Avenue
 West Molesey
 Surrey, UK
 KT8 2UZ

As the manufacturers of the apparatus listed, declare under our sole responsibility that the products listed below:

Pressure, Pressure Difference, Temperature & Flow switches series "W" or "A":
 201, 202, 203, 281, 204, 207, 208, 209, 231, 232, 233, 234, S21, S22, S24, GR2, GR4, VM2, VM4.
 301, 303, 304, 381, 384, 306, 386, 310, 316, S31, S34, GR3, GR6.
 721, 731, 771, 722, 732, 772, 723, 733, 773, 781, 734, 774, 741, 742, 743, 744, S71, GR7.
 131.

To which this declaration relates are in conformity with the following relevant standards or parts thereof:

- EN 60947-1 :1992 Low voltage switch gear and control-gear-general rules.
- EN 60947-5-1:1992 Low voltage switch gear and control-gear-control circuit devices and switching elements.
- EN 60529: 1991 Specification for classification of degrees of protection provided by enclosures.
- EN 60950:1992 Safety of information technology equipment including electrical business equipment: section 2.5.
- BS 6134:1991 Specification for pressure and vacuum switches.

And thereby conforms to the requirements of the Low Voltage Directive 73/23/EC amended by 93/68/EEC.

Signed:

R. Harrison
 Managing Director

Original dated 22nd June 2000
 Rev. B dated 12th August 2009

