

# Smart 2HT transmitter



Issue Nov 09

## How can we help you?

Technical Datasheets and IOM Instructions for all Delta Controls' pressure and temperature measurement products are available from our website at [www.delta-controls.com](http://www.delta-controls.com).

For Service and Repair enquiries, please contact the Sales Engineering Teams on +44 (0)20 8939 3500 or email [sales@delta-controls.com](mailto:sales@delta-controls.com).

### Delta Controls Limited

Island Farm Avenue, West Molesey, Surrey KT8 2UZ, UK

T +44 (0) 20 8939 3500 F +44 (0) 20 8783 1163 E [sales@delta-controls.com](mailto:sales@delta-controls.com) W [www.delta-controls.com](http://www.delta-controls.com)



## CONTENTS

Warranty	-----	3
Glossary	-----	3 - 4
Product Introduction	-----	5
Features		
Sensor, Electronics	-----	5
Software & Local Display	-----	5 - 6
Installation		
General	-----	6
Mechanical	-----	7
Electrical	-----	7 - 9
Commissioning		
Blind Instrument	-----	9 -10
Multi-Drop	-----	11
Trouble Shooting	-----	11
Specifications		
Functional, Performance	-----	12
Physical & Drawings	-----	13
Certified Products	-----	14-15
Options, Spares and Maintenance		
Re-Calibration Procedure	-----	16
Product code	-----	17

## WARRANTY

This instrument is guaranteed against faulty workmanship and material for a period of one year from the date of delivery. The company undertakes to repair, free of charge, ex-works any instrument found to be defective within the specified period provided the instrument has been used within the specification in accordance with these instructions and has not been misused in any way. Detailed notice of such defects and satisfactory proof thereof must be given to the company immediately after the discovery and the goods have to be returned free of charge to the company, carefully packed and accompanied by a detailed failure report.

## HEALTH AND SAFETY

To comply with health and safety requirements, any returned instrument must be clean and safe to handle and accompanied by a formal statement to that effect duly signed by an authorised officer of the user company. Any instrument returned without certification will be quarantined and no action will occur until cleared. We reserve the right to refuse to handle, and to return to the user, subject to transportation charge, any instrument for which a declaration of safety is not received.

## COPYRIGHT

Copyright © 1994 - 2007 Delta Controls Limited. All rights reserved. No part of this publication may be reproduced, stored in a retrieval system or transmitted in any form or by any means without the express prior written permission of Delta Controls Limited.

Copyright © 1994 - 2007 Delta Controls Limited. All rights reserved. All software and firmware supplied with this instrument, on disc or embedded are the sole property of Delta Controls Limited.

## DISCLAIMER

Delta Controls Limited does not authorise or warrant any product for use in life support devices and/or systems without the express written approval of an officer of the Company. All information contained within this manual is provided in good faith as a guide only; for specific applications, Delta Controls Limited should be contacted directly. The information contained within this manual is subject to change without notice.

## NOTE

HART® is a registered trademark of the HART Communication Foundation.

Hastelloy C® is a registered trademark of Cabot Corporation.

Monel® is a registered trademark of International Nickel Co.

## GLOSSARY

<b>Characterise</b>	Factory procedure used to calibrate the electronics so that sensor errors and temperature shifts are eliminated.
<b>Configurators</b>	To take advantage of the extra features within a smart transmitter a "configurator" is used. This normally allows viewing and editing of variables via a keyboard and integral display.
<b>Damping</b>	Software function used to increase the response time of the transmitters analogue output. This helps to smooth the output when there are rapid input variations.
<b>Descriptor</b>	A sixteen character field for additional identification of the field device, this may contain its plant location, or name.
<b>EEPROM</b>	Electrically erasable programmable read only memory, that retains its memory even during long term power removal
<b>EMC</b>	Electro Magnetic Compatibility, the ability of a product to function without influencing any other product, or being influenced
<b>HART®</b>	<u>H</u> ighway <u>A</u> ddressable <u>R</u> emote <u>T</u> ransducer. This protocol has become the de facto standard for digital communications with smart field devices. The HART® Communications Foundation is the owner of the registered trademark and provides support for end users and developers.

<b>LRL</b>	Lower Range Limit (pressure): The lowest measured value (pressure) that the transmitter can sense, governed by the sensor.
<b>LRV</b>	Lower Range Value (pressure): Normally the lowest measured value (pressure) that the analogue output (mA) of the transmitter can represent, but this may be reversed with URV (pressure) for reverse analogue outputs (mA).
<b>Master</b>	Name used to describe any system that is in control of the slave field devices, HART can support two masters, primary and secondary.
<b>Message</b>	A thirty two character field for additional information, name of installation engineer, calibration technician etc.
<b>MODEM</b>	Modulator \ Demodulator: a device that converts serial computer signals to and from an FSK (Frequency-Shift-Keyed) format.
<b>Multidrop</b>	This mode allows several field devices to share a common twisted pair of cables, a total of 15 devices may use one cable.
<b>Polling Address</b>	Unique number (1 - 15) used to identify an instrument when it is used in a multi-drop circuit. Transmitters that are not used in a multi-drop configuration have a poll number of zero.
<b>Protocol</b>	A set of rules or specifications that defines the structure of a communications language.
<b>PV</b>	Prime Variable, in this case pressure.
<b>Re-ranging</b>	Function that allows the transmitters analogue output to be scaled differently from the sensors upper and lower range limits (pressure).
<b>SV</b>	Secondary Variable, in this case temperature.
<b>Slave</b>	Name used to describe any device that will respond when requested to by a master.
<b>Smart</b>	A generic name used to describe any field device that can be configured from a remote location, and shows some form of intelligence.
<b>Span</b>	Difference between the upper and lower range values (pressure).
<b>Sputtering</b>	A process used to bond glass and other materials to each other at a molecular level.
<b>Tag</b>	An eight character field for identification of the transmitter, this is used in long frame format to build the unique identifier
<b>URL</b>	Upper Range Limit (pressure): The highest measured value (pressure) that the transmitter can sense, governed by the sensor.
<b>URV</b>	Upper Range Value (pressure): Normally the highest measured value (pressure) that the analogue output (mA) of the transmitter can represent, but this may be reversed with LRV (pressure) for reversed analogue outputs (mA).

## **PRODUCT INTRODUCTION**

The Delta HT Series of SMART transmitters accurately measures gauge or absolute pressure and transmits a traditional 4-20 mA signal as well as a digital signal using the HART® protocol. The HART® protocol gives the ability to integrate into one system, products from different manufacturers with predictable functionality and control. HART® has become the most widely used digital communication system for process instruments and controllers.

These transmitters complement the popular Delta 387 transmitters. Digital technology has been used to ensure accuracy, stability and range-ability across the full temperature range. Like its smaller brother the HT series of transmitters features a robust all stainless steel case.

The extensive use of surface-mount components and custom micro-power devices has resulted in a transmitter that is small, light and self supporting, although pipe mounting brackets are available if required.

In addition to the remote digital communications, the unit has, as standard, local zero and span adjustment at the touch of a button. If more than just local span and zero are required, there is a local display module available, the D-CAL. This can directly access more than 80% of the SMART transmitter's commands, for installation, commissioning and maintenance checks. The display may be fitted within the unit with no change to the external dimensions or supplied in a small hand-held case for repeated use when configuring blind instruments.

The transmitter is manufactured within a quality system, approved to ISO 9001:2000.

## **FEATURES**

### **THE SENSOR :-**

Gauge and Absolute Pressure - The preferred sensor below 10 Bar is a precision piezo-resistive transducer, with a silicone fill and a 316 stainless steel diaphragm. Above 10 Bar the sensor is a one piece, machined diaphragm with a sputtered thin film strain gauge. The diaphragm is specially designed to optimise the sensor for each range. The wetted parts of the sensor (diaphragm and inlet) can be selected from stainless steel, Monel or Hastelloy C to suit the process fluid being used. Gauge or absolute reference can be offered on all ranges.

### **THE ELECTRONICS :-**

The heart of the HT transmitter is an electronics module that uses surface mount technology and a 16 bit micro-controller, supervising all functions of the transmitter and performing continuous self checks to make sure the software is running properly.

The micro-controller takes the digital output from the sensor electronics and, using calibration coefficients, compensates the sensor signal for linearity and local temperature. Because the actual pressure is now digitised, any mathematical function may be applied to change the output. This allows conversion between different engineering units to be shown and square root extraction to be applied where required.

Any changes to the transmitter configuration are stored in EEPROM which is non volatile in the event of power supply failure. If a power failure occurs the transmitter will restart safely and signal digitally to a controller that a power failure has occurred.

The digital, linearised signal is fed to the output circuits. One signal is converted into a 4 to 20 mA current, the other is a superimposed audio tone conforming to the HART® protocol.

The input and output circuits of the transmitter are fully protected against over voltage, reverse polarity and RFI ; the local display/configurator is IP rated and protected against RFI.

### **THE SOFTWARE :-**

The software controls all functions of the transmitter, continuous self-diagnostics, communications, pressure calculations and display (if fitted). The firmware program is permanently stored within the micro-controller, all calibration and run time variables are stored in EEPROM. The software has built-in checks for sensor failure, loss of voltage reference and many other very unlikely failures. The software also contains complex algorithms for temperature and sensor linearisation, to mathematically characterise the sensor and electronics over its full temperature range to guarantee accuracy and repeatability. Within the software there is also a powerful state machine which is the set of statements that make decisions within the local configurator, and allows the transmitter to be set up as required.

## THE DISPLAY / CONFIGURATOR (“D\_CAL”) :-

The Local display unit is constructed from a single stainless steel puck that when fitted gives the transmitter a protection rating of IP 54 with the cover removed. The unit continuously shows prime variable and units of measure in monitor mode. If current or percentage output is required, then this may be selected on the D-CAL. The display unit also allows access to the state machine that generates a user friendly menu with access to the internal HART® functions that are commonly used for installation and maintenance.

To browse, edit and store information from the menu two buttons are used, CHANGE and SELECT. The SELECT button, when held for 2 seconds, saves a selected value to EEPROM. If the selection is invalid or out of range the transmitter will not store the change and will reply {REJECTED}.

For full detail, see the D-CAL Manual

## INSTALLATION ( GENERAL )

The final accuracy of the transmitter depends to a great extent on the proper installation of the unit and impulse piping. Care should be taken to minimise the effects of vibration, shock and temperature fluctuations. Care should also be taken to make sure that the transmitter is in a accessible position, where possible.

Before installation of the unit, ensure that the pressure range and maximum working pressures selected are compatible with the expected system pressure. Adequate lengths of impulse lines, or siphons should be used to ensure that very high temperature process media do not come into direct contact with the unit. Precautions should also be taken against the media freezing within the unit.

As the best location for the transmitter in relation to the process depends upon the process medium, please consider the following points before installation.

- Keep all impulse lines as short as possible, and of the same length.
- Avoid high points in liquid and low points in gas lines.
- Use piping large enough to prevent blockage.
- Make sure there are no unaccounted static heads that will give false readings.
- Make sure that the transmitter is isolated from high process temperatures.

The 2HT is designed to be self supporting and can be mounted in any position. Brackets are, however, available should wall or pipe mounting be required.

The pressure connection should be tightened using a 50 mm ( 2" ) AF spanner on the flats of the lower body, and the appropriate spanner on the pipe-work connector.

**DO NOT USE A COMPRESSION WRENCH ON THE 2HT BODY TO TIGHTEN THE PRESSURE CONNECTION.**

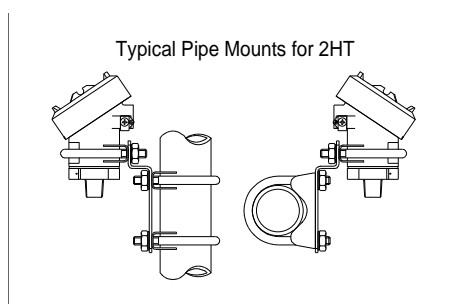

## **MECHANICAL INSTALLATION**

### **Conduit connection**

The 2HT series Transmitters are supplied with either M20 x 1.5 or 1/2" NPT internally threaded electrical connection. To prevent condensation build-up in the conduit entering the instrument housing, the following piping layout should be followed. Additional considerations must be made if transmitters are to be mounted in hazardous areas.

If cable is used a suitable gland should be chosen so that protection rating and hazardous area certification is not affected, in accordance with site or national codes of practice.

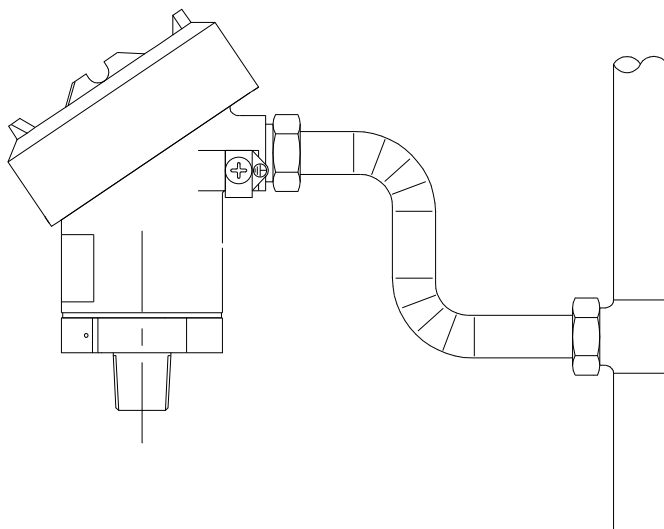

## **ELECTRICAL INSTALLATION**

### **Cable selection**

The HART protocol is designed to be used over conventional instrument cables, but there are limitations on the usable length, depending on the type of cable used. These limitations are concerned with two things :-

- (i) keeping interference at a level low enough not to affect the reliability of the communication, and
- (ii) ensuring a proper signal level at the receiver.

### **Interference.**

Each HART loop consists of a pair of wires, these should be twisted together to reduce interference from external electromagnetic fields. Please note that the full benefit of a twisted pair is not obtained because the HART signal is not symmetrically balanced on the two wires. For all but the very shortest cable runs, screening is necessary for protection against interference. There may be a single screen covering a number of twisted cables, or, better, each twisted pair may have its own individual screen. All screens should be connected together and connected to ground at one point only, typically near the control room.

### **Signal Level**

The main factor that affects the signal level is cable capacitance. The signal level is degraded as the cable capacitance rises. As a general rule the product of the total resistance and the total capacitance must be less than 65 microseconds.

$$(R_{load} + R_{barrier} + R_{miscellaneous}) \text{ ohms} \times (C_{cable} + C_{devices}) \text{ farads} \leq 65\mu\text{S}$$

Cable capacitance is measured per meter so multiply the nominal value by the length of cable run. For each HART device allow 5 nF x the CN number.

To limit the possible effects of interference and signal degradation the following rules are imposed in the HART specification :-

Maximum overall length, individually screened pairs :- 3000 metres

Maximum length, multiple pairs with only an overall screen :- 1500 metres

Do not mix non-HART compatible signals within the same cable run.

Cable should be run through a sealed metal gland rated IP66, to avoid moisture ingress in to the housing and provide a strong mechanical fixing. For EEx d applications the use of approved cable and glands is a mandatory requirement

**Recommended wiring practice**

It is recommended that the field wiring be trimmed to length as follows. This will then allow access to the zero and span buttons and prevent fouling of the display cable if fitted.

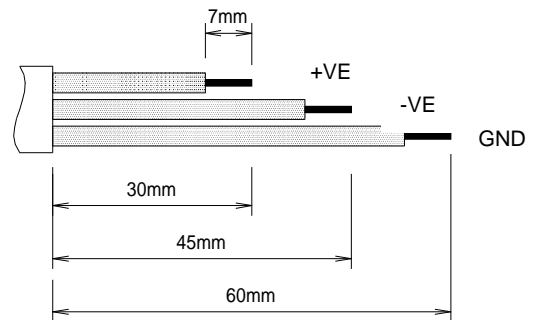

**Recommendations for Power supply :-**

The DC power supply should have less than 2% ripple, and be able to source at least 24 mA for a single transmitter and 100 mA for a multi-drop system, at a nominal 24 volts.

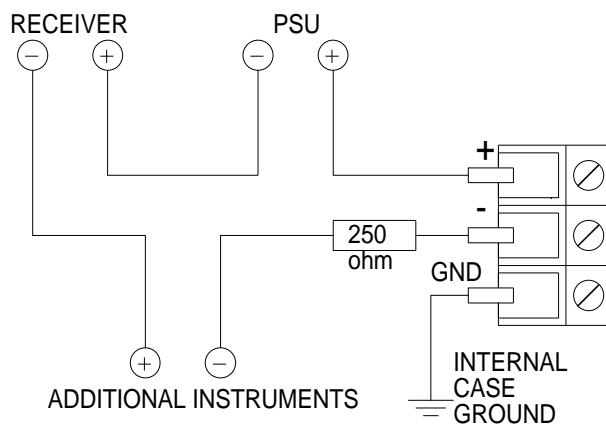

The terminal block inside the instrument has three connections, signal, return and ground. For convenience there is an internal ground as well as two external connections. The Delta transmitter will run with reverse polarity and has over voltage protection as standard.

## Loop load

The required loop voltage is based on the loop resistance. To determine the total resistance, add the resistance of all the units within the loop (except the transmitter). The required supply voltage can be determined by reference to the graph. Note that there must be a minimum of 250 ohms within the loop for digital communication to take place.

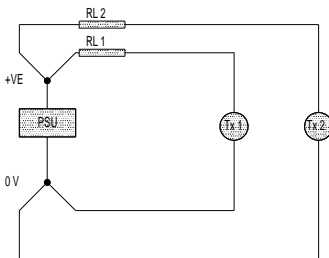
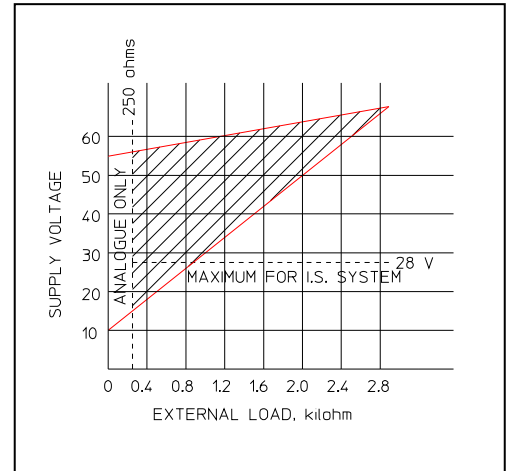

## Factors to be considered.

The ideal system with no cross-talk, this assumes that the PSU has zero impedance at the HART signalling frequencies. Note that separate positive and ground lines are run to each instrument. Cables are spaced, or screened, to prevent capacitive coupling between loops.

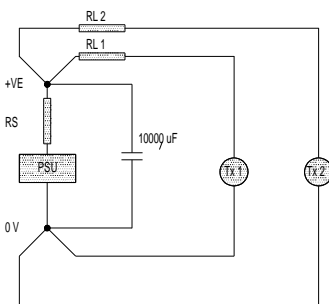

The HART protocol requires the PSU series resistance (RS) to be less than 10 ohms. Most power supplies will meet this requirement, but with the addition of distribution wiring and in line fuses care must be taken. If required a 10000 uF electrolytic capacitor of suitable working voltage may be connected across the common terminals for the HART loop.

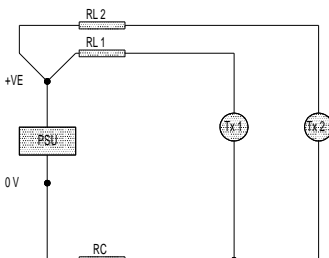

Common resistance (RC) this can be caused by high cable resistance, or by grounding multiple loops in the field rather than in the control room. To prevent high cable resistance resulting from grounding null loop, each loop wire should be wired back to the psu.

## COMMISSIONING

The Commissioning and Transmitter Function sections of this manual assumes a blind instrument or one fitted with a DELTA local display Configurator. Blind instruments can be re-ranged and zeroed as standard, using the one touch Zero and Span Buttons.

When the transmitter is shipped it has a fixed upper and lower range limit (URL, LRL) that is dictated by the sensor used. The upper and lower range values can be set, (URV, LRV) to any value from LRL to URL so long as the minimum span is not breached. The URV can be set lower than the LRV this will reverse the transmitter's analogue output, and give a 20 to 4 mA output.

The engineering units that are displayed and transmitted by the unit may be changed.

There are four ways to re-range the transmitter, each one makes changes to the setting of the URV and LRV.

- 1 :- With the zero and span buttons that are fitted on a blind instrument.
- 2 :- Enter a URV and LRV directly from the "DCAL" configurator (D-CAL).
- 3 :- Use the Zero and Span options from the local display.
- 4 :- Using a Universal Hand-held communicator (e.g. Rosemount 375)

## Re-ranging using the Zero and Span Buttons, Blind Instrument.

The transmitter can have its LRV and URV set using the local keys mounted on the top circuit board. To set these values a pressure source should be used that has a calibrated accuracy three to five times better than the desired instrument accuracy, a loop current indicator is also required. Alternatively the instrument can use the process to generate the required pressures.

- 1 :- Apply the LRV pressure to the instrument.
- 2 :- Wait 20 seconds, for the pressure to stabilise.
- 3 :- Press the **[ZERO]** button and hold it for 3 seconds.
- 4 :- Check the loop current equals 4 mA.
- 5 :- Apply the URV pressure to the instrument.
- 6 :- Wait 20 seconds, for the pressure to stabilise.
- 7 :- Press the **[SPAN]** button and hold it for 3 seconds.
- 8 :- Check the loop current equals 20 mA.

For reversed analogue output the zero and span buttons are pushed in the reverse order, swap over commands 3 and 7. To initially reverse the current output it will be necessary to set the zero (LRV) to at least 5% of the instrument's full range so that when the span key is pressed the change is not rejected by the minimum span limit.

Note: the lower and upper range values must fall within the lower and upper range limits, and meet the minimum and maximum span specifications allowed by the transmitter, if they do not the zero or span will not be set.

### Zero, Span and Rangeability

#### Forward Action, 4 to 20 mA

Apply the lower range value. This may be achieved once the unit is installed, or in the workshop with a pressure source. Allow the unit to settle. Press and hold the zero key for two seconds. 4 mA output will be set.

Apply the upper range value. Allow the unit to settle, press and hold the span key for two seconds. 20 mA output will be set.

If the unit is being re-ranged rather than being trimmed the zero may need to be checked to achieve full accuracy.

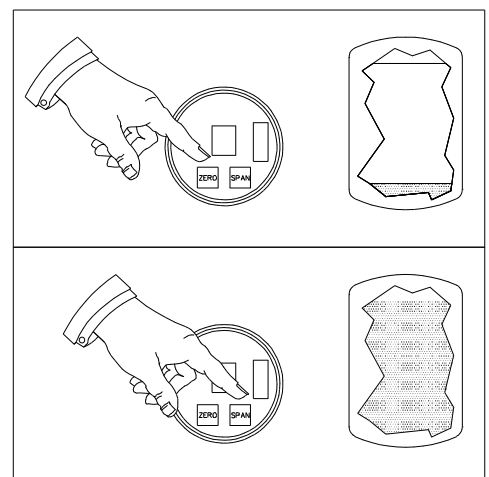

#### Reverse Action, 20 to 4 mA

Apply the lower range value. This may be achieved once the unit is installed, or in the workshop with a pressure source. Allow the unit to settle. Press and hold the span key for two seconds. 20 mA output will be set.

Apply the upper range value. Allow the unit to settle press and hold the zero key for two seconds. 4 mA output will be set.

If the unit is being re-ranged rather than being trimmed the zero may need to be checked to achieve full accuracy.

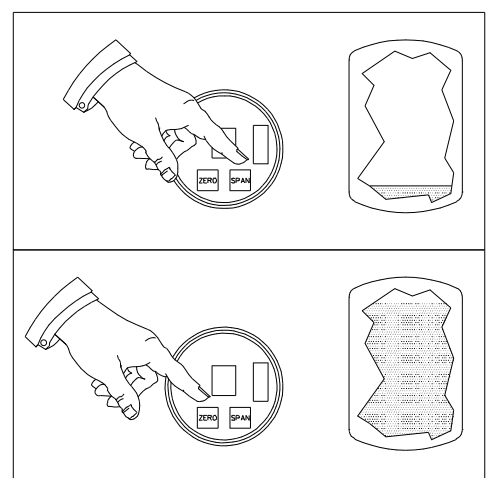

**These buttons are automatically disabled when the DCAL is plugged in via its 10-way IDC connector. They may also be remotely disabled over the HART® network.**

## **MULTI-DROP CONFIGURATION**

Multi-dropping transmitters refers to the practice of connecting several units to a single transmission line. The analogue signal is switched to 4 mA on all units and communication takes place digitally only. Each message is sent with a unique number that identifies the field device.

The HART® system limits the number of instruments that can be connected in this way to 15. For Intrinsically Safe installations, maximum permissible circuit current reduces the limit to four. When a multi-drop system is designed, consideration must be given to the length of transmission line, update rate required from each transmitter and total power requirement. Multi-drop systems are not recommended for Intrinsically Safe installations. Each transmitter is identified by a unique number from 1 to 15 and responds to HART® commands that are sent to that address.

Note that the transmitter is sent from the factory with its address set to 0 this disables multi-drop and allows 4 to 20 mA and digital communication only.

There is no way to change the polling locally. This is for safety reasons, so that the address can only be changed once digital communication has been established from Hart master.

The use of a separate HART® Multiplexer is permissible, but outside the scope of this manual.

## **TROUBLE SHOOTING**

The integrity of a HART® loop can be validated using several methods, if a local display is fitted the {SHOWHART}, {FIXLOOP} and {SELFTTEST} methods provide a high level of confidence, for lower level testing or if a local display is not present the use of a simple oscilloscope and voltmeter can be used.

Note: in an Intrinsically Safe application restrictions may apply to the instruments being used.

### **Analogue Loop Tests.**

Is the voltage at the instrument, across the terminals, above the lift-off voltage of the instrument, typically 9 to 12 volts, see the functional specifications?

Measure the DC voltage across the load resistor, derive the loop current using the calculation :-

Loop Current = DC Voltage / Load Resistor

This should be between 4 and 20 mA and representative of the measured prime variable, unless the device is in multi-drop mode where the current will approximately equal 4 mA multiplied by the number of devices within the loop.

Is the loop grounded properly, normally in one place, at the power supply?

Is the screen of the cable grounded at one end only, normally at the control room?

Are the cables isolated from other high current cables?

Is the cable of the correct grade and not too long, see cable selection and signal level?

Are the barriers HART compliant and is the power supply low impedance?

## **FUNCTIONAL SPECIFICATIONS**

Service :-	Liquid, Gas or Vapour
Ranges :-	0 ~ 1 to 0 ~ 1000 Bar ( 0 ~ 16 to 0 ~ 16,000 psi )
Sensor Limits:-	2 * URL Overpressure Stainless Steels except range GA, 0 to 1000 bar = 1.5 * URL 1.5 * URL Overpressure Monel & Hastelloy
Output :-	4 to 20 mA DC 2 Wire System with digital AC signal superimposed on to it, using the HART protocol.
Power Supply :-	9 to 55 Volts DC (Subject to 28 V maximum on Intrinsically Safe installations)
Load Limits :-	Dependent upon installation and PSU, See chart in Electrical Installation
Hazardous Area Certifications :-	See Certified Products
Zero Elevation & Suppression:-	Can be set anywhere within the sensor limits as long as the span is greater or equal to the minimum span, and URV does not exceed URL
Normal or Reverse action :-	Set by reversing the upper and lower range values. See Zero, Span and Rangeability
Temperature Limits:-	Operating :- -40 to +85 Degrees C Storage :- -50 to +110 Degrees C Display :- -30 to +80 Degrees C
Failure Mode Alarms:-	High or Low (Analogue) for a major transmitter malfunction.
Humidity Limits :-	0 to 100% RH
Turn-on Time :-	Less than 6 Seconds, This includes full self diagnostics
Volumetric Displacement :-	< 1 microlitre
Damping :-	0 to 39 Seconds, in addition to the sensor response time.

## **PERFORMANCE SPECIFICATIONS**

Accuracy	For spans of 1 : 1 to 10 : 1 +/- 0.1 % of SPAN, Including Linearity, Hysteresis and Repeatability For spans below 10 : 1 +/-0.15 % of SPAN
Stability	Typically less than 0.15 % URL per annum
Temperature Effect	Total effect +/- 0.10 % at Max. Span over ambient range
Overrange Effect	Zero shift, 0.2 % of URL
Power Up	Less than 6 seconds, including Diagnostics, Display and Memory tests
Vibration Effect	5 g Peak sinusoidal at 5 Hz to 200 Hz without deleterious effect
Power Supply Effect	<0.005% of URL per volt
Mounting Position Effect	Zero shift, less than 10 mm H <sub>2</sub> O for a 10° tilt in any plane.
RFI Effects	With the cover on and/or display in place, in accordance with IEC 6100-4-3, 80 Hz to 1 Ghz at 10 V/m, 1 GHz to 2.7 GHz at 3 V/m. See Declaration of Conformity for the EMC Directive 89/336/EEC. For full compliance with susceptibility performance, the screen of the cable must be directly connected to the enclosure via a cable gland that makes a 360° connection.

## PHYSICAL SPECIFICATIONS

Electrical connections :-	Female M20 x 1.5 or Female ½ " NPT
Process Connection :-	½ " NPT External, G ½ " A to ISO 228 or High Pressure Cone and Thread ("Autoclave")
Process Wetted Parts :-	Below 10 Bar 316 St. St. inlet and Diaphragm 316 St. St. inlet with 17-4PH or 15-5PH Diaphragm as standard; Monel and Hastelloy available.
Non- Wetted Parts :-	Lower body, Case & Lid :- 316 Stainless Steel Mounting Hardware :- 316 Stainless Steel
Protection :-	IP 66
Mounting :-	Direct process mounting as standard. On 50 mm dia. ( 2" ) pipe using mounting bracket kit. Wall mounting with kit.
Weight :-	1.6 kg ( 3.5 lb ) Blind Instrument Display, add 200 grams ( 0.44 lb )

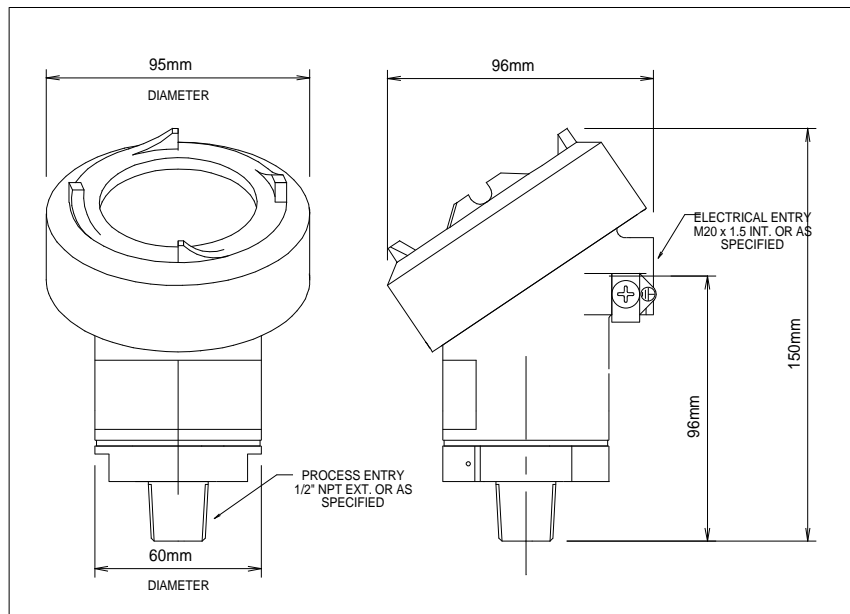

Dimensions are  
Approximate

## WEATHERPROOF

### **Models A2HT, R2HT, F2HT, 42HT**

The instruments have been tested for dust and water penetration to EN 60529 and have been rated IP66 with cover in place and conduit entry suitably sealed. Third party test report for water available on request.

In addition, the instruments, when fitted with the built-in D-CAL configurator, meet IP54 requirements, enabling configuration to be performed under damp conditions. **DO NOT LEAVE INSTRUMENTS OPEN UNNECESSARILY!**

## CERTIFIED PRODUCTS

### FLAMEPROOF

#### **EEx d :- Model R2HT**

Apparatus Certificate Number :- ITS03ATEX11187

Compliance with EN 50014:1997, EN 50018:2000  II 2 G. See Declaration of Conformity for ATEX.

EExd IIC T4 (Tamb = -40 to +85°C)

EExd IIC T6 (Tamb = -40 to +60°C)

#### **Note:**

Flameproof model R2HT with display fitted (see page 17, signal input code 2 or B) gas group reduced to II B+ H<sub>2</sub>

EExd IIB+H<sub>2</sub> T4 (Tamb = -40 to +85°C)

EExd IIB+ H<sub>2</sub> T6 (Tamb = -40 to +60°C)

### INTRINSICALLY SAFE

#### **EEx ia Approval :- Model 42HT**

Apparatus Certificate Number :- ITS03ATEX21213X

EN 50014:1997 + Amds 1 +2, EN 50020:2002, en 50284:1999

EEx ia IIC T4 T<sub>amb</sub> 80°C  II 1 G See Declaration of Conformity for ATEX.

Safety Parameters :-

Ui	=	30 Volts
Ii	=	130.9 mA
Pi	=	0.66 Watts
Li	=	30 uH
Ci	=	16 nF

#### **Special Conditions :-**

1. The pressure transmitter may be fitted with an integral display or alternatively, when the blanking plate is removed, a hand held display may be inserted into the socket provided. The removal of the blanking cover is only permitted in a non-hazardous area.
2. The pressure transmitters intended for operation at 50 V dc do not meet the requirements of EN 50020:2002 clause 6.4.12 (Electrical Strength Test). This shall be taken into account when installing the apparatus in a potentially explosive atmosphere.

### SYSTEM

The user/installer is responsible for ensuring the safety parameters of the circuit/system are not exceeded. Refer to IEC 60079 -14: Electrical apparatus for explosive gas atmospheres - Electrical installations in hazardous areas (other than mines) and EN 60079 -25: Electrical apparatus for explosive gas atmospheres - intrinsically safe systems

### USA EXPLOSIONPROOF AND INTRINSICALLY SAFE

#### **FM:- Model F2HT**

**F2HT** Report Number 1B5A6.AE

Approved for Explosionproof Class I, Division 1, Groups B C & D

Dust-Ignition-Proof Class II/III, Division 1, Groups E F & G

Intrinsically Safe Class I, II, III Division 1, Groups A B C D E F & G

(Entity requirements, Control Drawing No 2/14307, Entity Parameters: V Max =30 V, I Max = 130.9 mA, Ci = 8.85 nF,

Li = 30 uH, P Max = 0.67 W) NEMA 4X

AMENDMENT	DATE	BY
AMENDED	06.03.88	REF. SH. 2322
AMENDED	14.01.87	REFER TO JOB SH. 2335
AMENDED	19.03.87	REFER TO JOB SH. 2341
AMENDED	01.04.87	REFER TO JOB SH. 2361
AMENDED	08.04.87	REFER TO JOB SH. 2361
AMENDED	22.05.87	REFER TO JOB SH. 2403
AMENDED	24.06.87	REFER TO JOB SH. 2442

NON - HAZARDOUS LOCATION

HAZARDOUS LOCATION  
 CLASS I DIV 1, GP A, B, C, D  
 CLASS II DIV 1, GP E, F, G  
 CLASS III DIV 1

ITEM 4  
 ANY APPROVED LOOP POWERED DEVICE  
 IS TO BE INSTALLED IN ACCORDANCE  
 WITH OWN CENTRAL DRAWING

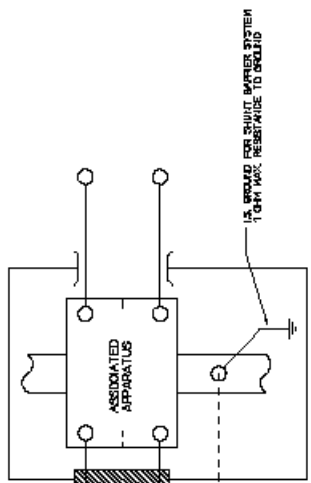

ITEM 2  
 ASSOCIATED APPARATUS  
 ANY APPROVED ASSOCIATED  
 APPARATUS WITH ENTRY  
 CONCEPT PARAMETERS:  
 V<sub>oc</sub> = 28V  
 I<sub>sc</sub> = 9.23mA

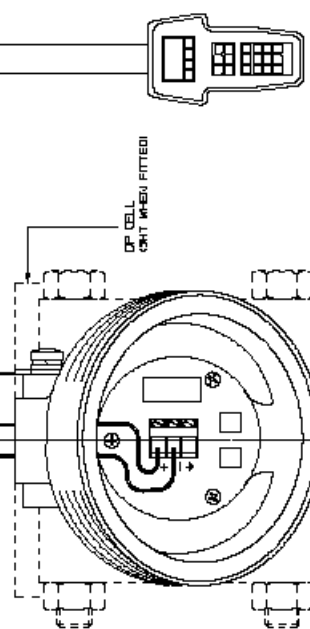

ITEM 3  
 ANY APPROVED HAND HELD  
 DISPLAY UNIT IS TO BE USED FOR  
 USE IN HAZARDOUS LOCATION.  
 INSTALL IN ACCORDANCE WITH  
 OWN CONTROL DRAWING

ITEM 1  
 COMPRISES A DELTA CONTROLS PRESSURE  
 TRANSMITTER TYPE F-2HT AND DP CELL  
 TYPE 3HT WHEN FITTED. THE TRANSMITTER  
 CAN BE USED IN CONJUNCTION WITH AN INTEGRAL  
 OR HAND HELD DISPLAY UNIT.

V<sub>oc</sub> = 30V  
 I<sub>sc</sub> = 0.267mA  
 C<sub>i</sub> = 0.25nF  
 L<sub>i</sub> = 30uH  
 P<sub>max</sub> = 0.67W

THE TRANSMITTER ENCLOSURE IS RATED IEMA 2X  
 IS -25°C TO +50°C

NOTES  
 1. SYSTEM PARAMETERS  
 PERMITTED SYSTEM CAPACITANCE AND INDUCTANCE  
 ACCOUNT MUST BE TAKEN ON CABLE AND LOOMS

GROUPS	C <sub>s</sub>	L <sub>s</sub>
A/B	20nF	197nH
C	245nF	4.57nH
D	795nF	14.97nH

2. THE INSTALLATION MUST BE IN ACCORDANCE WITH  
 THE NATIONAL ELECTRICAL CODE, IEEA 70, ARTICLE  
 504 AND ANSI/ISA-81.26

SCALE 1:1

TOLERANCES  
 FOR ALL PRODUCTION  
 & QUALITY PROOFING  
 SEE DELTA STANDARD  
 QCP 4.5  
 FORMERLY QP21  
 MATERIAL

2 REF. SIZE

STOCK No.

TOOL No.

FINISH

USED ON

ASSOC. DRAW

DRAWN P.S.

TRACED

CHECKED P.S.

DATE 24.09.87

FM Certified Product No modifications  
 permitted without reference to:  
 Factory Mutual Research Corporation

DELTA CONTROLS LTD. ISLAND FARM AVENUE  
 WEST MOLESEY  
 Surrey KT8 2JZ

F-2HT/3HT INTRINSICALLY SAFE CONTROL DRAWING

RELEASED FOR MANUFACTURE  
 DRAWN P.S.  
 CHECKED P.S.  
 APPROVED FOR TOOLING  
 DRAFTSMAN  
 2 14307

## OPTIONS

- Mounting** Stainless steel wall and pipe clamps are available as an optional way of mounting the unit.
- Display / Configurator** The D-CAL configurator / display may be ordered with the transmitter or retrofit at a later date, without compromise to the certifications. This unit is not loop powered and can only be used with the Delta Controls HT range of SMART Transmitters.

## SPARES

Lid 'O' Ring	:-	Spares No.	155042
Display 'O' Ring	:-	Spares No.	155043
Display Overlay	:-	Spares No.	9020311
Lid ( Free Blank )	:-	Spares No.	9420004
Lid ( Free Windowed )	:-	Spares No.	9400123
Display Assembly	:-	Spares No.	9400124

## MAINTENANCE

The unit requires no maintenance as standard, but it is recommended that all cable terminals be checked for tightness at standard site maintenance intervals. Please note that all of the circuit boards within the unit are protected against water damage so it is unnecessary to apply any other form of protection, as this may void the products warranty.

## RE-CALIBRATION

The 2HT series instruments are designed for long and stable lifetime operation.

The nature of a combined analogue / digital instrument such as this, is that the Analogue to Digital Converter that processes the sensor input measures the total permitted pressure range of the instrument, irrespective of the chosen output of the 4 to 20 mA range. Changes in the selected 4 to 20 mA output are made against the stored, compensated values of pressure conversion.

From time to time, however, it will be necessary to check, and, if required, trim the scaling of the A-D converter against a local pressure standard.

The method used by the 2HT series, assumes that the two most important calibration points for the chosen application are the Lower and Upper Range Values set for the 4 to 20 mA output. These, **not the instrument's zero and nominal Upper Range Limit**, are the values to be applied to the instrument when trimming the ADC.

### **Apparatus Needed**

A accurate pressure supply (+/- 0.03% of value)  
A Delta D-CAL Communicator (as the procedure requires a Device Specific command, only software versions 5.00 and later may be trimmed via HART®)

### **Method**

Apply a pressure value equal to the instrument's selected Lower Range Value. In the ACCESS2 menu of the D-CAL, go to {TRIM LRV}{**SELECT**}

{HIT SAVE} will be displayed, there are two choices :-

**[SELECT]** or **[CHANGE]** To abort and return to the {TRIM LRV} menu

**[[SELECT]]** Press and hold for two seconds to store the ADC offset value, {SAVED} will be displayed to show that the command is successful.

Now apply a pressure value equal to the instrument's selected Upper Range Value, and repeat the above sequence, with {TRIM URV}.

The ADC is then set to the site standard. For full explanation of the D-CAL functions, see the D-CAL Configurator Manual.

## PRODUCT CODE

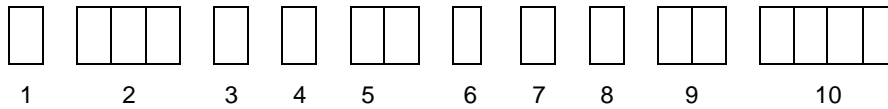

**Note that not all options are available on all models!**

1 :-	Enclosure	4 R A F	= = = =	EEx ia (Intrinsically Safe) EEx d Weatherproof Factory Mutual approved		
2 :-	Model,	2HT	=	Gauge and Absolute Pressure		
3 :-	Electrical Entry	1 2	= =	M20 Internal ½" NPT Internal		
4 :-	Wetted Parts	R S T U C D	= = = = = =	All 316 Stainless Steel 17-4PH or 15-5 PH Sensor, 316 Process connection All Monel All Hastelloy Hastelloy sensor, 316 Process connection 17-7 PH sensor, 316 Process connection		
5 :-	Ranges (Bar)	DA EA FA GA	= = = =	1 10 100 1000	D2 = 2 EB = 16 FD = 400	DE = 6 ED = 40 FE = 600
6 :-	Pressure Reference	G	=	Gauge    A = Absolute		
7 :-	Signal Output	1 2 A B	= = = =	Blind Instrument, 50 Volt Isolation Local Indicator, 50 Volt Isolation Blind Instrument, 500 Volt Isolation Local Indicator, 500 Volt Isolation		
8 :-	Process Connection	J N V	= = =	½ " NPT External G ½"A to ISO 228 "Autoclave" High pressure connections		
9 :-	Options and Treatments			Codes on Application		
10 :-	Special Engineering			Codes on Application		

### Delta Controls Limited

Island Farm Avenue, West Molesey, Surrey KT8 2UZ, UK

T +44 (0) 20 8939 3500 F +44 (0) 20 8783 1163 E sales@delta-controls.com W www.delta-controls.com

