

**GENERAL**

The unit is manufactured, checked and supplied in accordance with our published specification, and when installed and used in normal or prescribed applications, with the lid in place and within the parameters set for mechanical and electrical performance, will not cause danger or hazard to life or limb.

**HEALTH AND SAFETY AT WORK ACT 1974**

**WARNINGS**

1. THE USERS ATTENTION IS DRAWN TO THE FACT THAT, WHEN THE UNIT IS "LIVE" WITH RESPECT TO ELECTRICAL OR PRESSURE SUPPLIES, A HAZARD MAY EXIST IF THE UNIT IS OPENED OR DISMANTLED.

2. UNITS MUST BE SELECTED AND INSTALLED BY SUITABLY TRAINED AND QUALIFIED PERSONNEL IN ACCORDANCE WITH APPROPRIATE CODES OF PRACTICE SO THAT THE POSSIBILITY OF FAILURE RESULTING IN INJURY OR DAMAGE CAUSED BY MISUSE OR MIS-APPLICATION IS AVOIDED.

3. TYPE W AND A ENCLOSURES HAVE A SAFETY BLOW-OUT DISC FITTED IN THE REAR OF THE ENCLOSURE TO PREVENT DANGEROUS PRESSURISATION OCCURRING IN THE EVENT OF A BELLOWS FAILURE. THIS MUST NOT BE OBSTRUCTED DURING INSTALLATION. LEAVE AT LEAST 6MM CLEARANCE BETWEEN THE BACK FACE OF THE ENCLOSURE AND THE MOUNTING SURFACE. DO NOT REMOVE OR REPLACE WITH ANY OTHER DEVICE NOT APPROVED BY DELTA CONTROLS. DO NOT REMOVE AND REFIT BACKPLATE SO AS TO OBSTRUCT THE BLOW-OUT DISC.

**CAUTION**

Applied vacuum will damage some low pressure range instruments unless they are supplied in protected form.

**OPERATING PRINCIPLES**

A metal bellows is used to sense the process pressure. The bellows transmits a force proportional to the applied pressure to an operating beam. The beam is restrained by an adjustable spring. When the force on the beam overcomes the spring tension the beam moves and operates a switch or switches. On reduction of the applied pressure the force applied to the beam also falls, the beam is restored to its original position by the spring, and the switch resets.

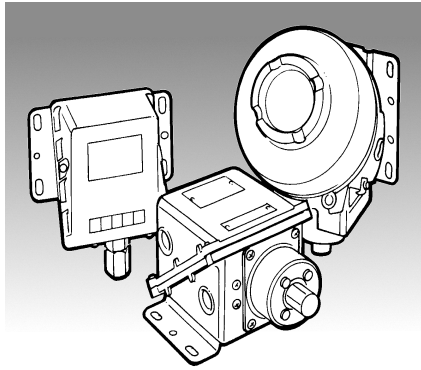

**PRODUCT CODE**

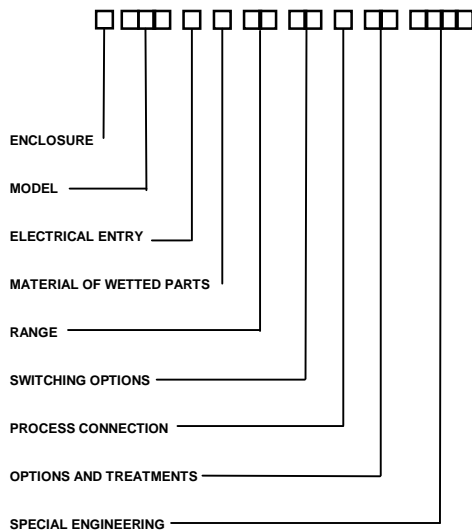

On enclosures H, and K, remove the lid using an appropriate tool if tight e.g. edge of spanner or metal rod (fig 1A).

**INSTALLATION**

The instruments are designed to be mounted vertically with the process connection underneath. They can be mounted either direct to process or to a wall or panel using the backplate provided. Select the mounting point so as to avoid excessive shock, vibration or temperature fluctuation. Instruments should be mounted to avoid excessive heat transfer from the process lines or adjacent plant.

If sudden changes of pressure (pulsation's) are likely then we recommend that snubbers are fitted between the process line and switch.

Use a spanner to support the process connection when fitting the instrument. When fitting the instrument lid make sure gaskets or 'O' rings are in good condition and fitted correctly.

**WARNING: CHECK THE CONNECTION THREAD SIZE AND SPECIFICATION ON THE UNIT TO AVOID MISMATCHING WITH THE PROCESS CONNECTION ADAPTOR. SEE DIGIT 11 OF PRODUCT CODE.**

**WIRING (Fig 1)**

Wire in accordance with local and National codes. Use cables no larger than 2.5 mm sq. (14AWG). Deliver electrical connection through a suitable cable gland which will maintain the IP rating of the instrument. Insert bare wires fully into the terminal block and tighten securely. Keep wiring tails to a minimum and check that wires do not interfere with the operating mechanism. Use the earthing points provided.

**CERTIFIED ENCLOSURES**

All Series 200 Pressure Switches can be supplied with BASEEFA certified enclosures to the following standards: **Zone 1 (Div 1) IEC 60079-0 and IEC 60079-1** BS 5501:Parts 1 and 5: EN50 014 and EN50 018 CENELEC Codes 'H' for aluminium and 'K' for cast iron 2GD Exd IIC T6

**Zone 2 (UK Only)**

BS 4683: Part 3, Enclosure Code "N". ExN IIT6

All enclosures are suitable for outdoor use and the majority of products are rated IP66. Refer to the product label and/or leaflet. Only operation, maintenance or repair procedures either contained herein or approved by Delta Controls may be used, to avoid rendering the equipment unsafe in operation and/or nullifying the Certification. NO MODIFICATIONS ARE PERMITTED.

**Electrical Adaptors**

**Zone 1.** Use only certified adaptors for Zone 1.

**WARNING: IT IS A REQUIREMENT OF SAFETY THAT AT LEAST 5 FULL THREADS ARE ENGAGED BETWEEN THE ADAPTOR AND CONDUIT ENTRY. TAKE CARE TO SELECT AND INSTALL ADAPTORS THAT DO NOT REDUCE THE ENCLOSURE IP RATING.**

**Zone 2.**

Adaptors used must have equivalent IP rating to the enclosure and be impact resistant to 7 Nm.

**References for Selection and Installation**

BS 5345 Part 3 for Enclosure Codes H and K  
BS 5345 Part 4 for all Enclosure Codes (Intrinsic Safety)  
BS 5345 Part 7 for Enclosure Code N  
BS 5490 IEC 529 IP RATING (Ingress Protection)

**MAINTENANCE**

Inspections should be carried out at quarterly to yearly intervals depending upon operating conditions. Isolate the unit from process and power and remove the lid. Check all terminals for tightness. Check that cable tails are not fouled or chafed. Check for internal condensation.

Rectify as necessary.

It is recommended that instruments used to provide an alarm are operated periodically to ensure they are functioning correctly.

If further maintenance is required seek advice from DELTA CONTROLS before attempting repair or replacement of parts.

**CAUTION**

Moving parts have been treated with a water repelling lubricant before leaving the factory. Occasional inspection and the application of a water repelling lubricant is recommended to ensure moving parts remain free under all conditions.

**WARNING: DOES NOT APPLY TO OXYGEN SERVICE.**

**Zone 1 enclosures**

Thread seal and contact surfaces must be lightly lubricated using a non-setting non-corrosive grease compatible with the nitrile lid seal. Do not use copper bearing grease on aluminium. Screw on lid hand tight making sure that mating surfaces of the lid and enclosure are in contact. Retighten the lid lock screw.

**WARNING: IT IS A SAFETY REQUIREMENT THAT AT LEAST 5 FULL THREADS ARE ENGAGED WHEN THE UNIT IS IN OPERATION. NEVER OPERATE THE UNIT UNLESS THIS CONDITION IS MET. DO NOT USE GREASES OR LUBRICANTS NOT COMPATIBLE WITH THE ENVIRONMENT OR PROCESS.**

**Weatherproof Enclosure (W) and (N).**

If lid gasket is dried out or damaged, replace with new greased gasket.

**Stainless Steel Weatherproof Enclosure (A)**

Check gasket. If damaged, replace.

**OPERATION**

Pressure switches are supplied calibrated against falling pressure unless otherwise specified. Set Point adjustment refers to falling pressure. Switching differential is the difference between the set point and the operating value on rising pressure. Before commencing adjustments or removing the lid, isolate the instrument from process and power. For opening details see Figs 1A, 6, 7, 8.

**Set Point Adjustment: Models 201, 202, 203 (Fig 2)**

- Loosen the M3 hexagon head locking screw.
- Rotate the 20 mm A/F hexagon head adjuster knob to move the indicator along the calibrated scale. Rotate clockwise to increase the set point and counter clockwise to decrease the set point.
- Retighten the locking screw taking care not to overtighten.
- Replace the instrument lid (See maintenance).

**Set Point Adjustment: Model 281 (Fig 3)**

The model 281 provides 2 microswitches which can be set independently against individual scales using a special dual beam mechanism. This fulfils the need for HI LO switching, adjust as follows:

- Loosen the rear M3 hexagon head locking screw.
- Rotate the rear adjuster screw to move the indicator on the right hand (LO) calibrated scale. Rotate clockwise to increase the set point and counter clockwise to decrease the set point.
- Retighten the locking screw.
- Loosen the front hexagon head locking screw.
- Rotate the front adjuster screw to move the indicator on the left hand (HI) calibrated scale. Rotate clockwise to increase the set point and counter clockwise to decrease the set point.
- Tighten the locking screw.
- Replace the instrument lid (see maintenance)

**Switching Differential Adjustment: Model 202 (Fig 4)**

- Rotate the knurled plastic wheel on the microswitch to adjust the switch differential. Rotate clockwise to increase the differential and counter clockwise to reduce the differential. **Note:** Rotating the knurled plastic wheel will alter the operating value on rising pressure only.

Replace the instrument lid (See maintenance).

**Switching Differential Adjustment: Model 203 (Fig 5)**

- Rotate the secondary adjuster screw to move the secondary indicator along the "arrow" scale. Rotate clockwise to increase the differential and counter clockwise to decrease the differential.
- Replace instrument lid (See maintenance).

**Note:** Rotating the secondary adjuster knob (screw) will alter the operating value on rising pressure only. For accurate setting, a suitable pressure gauge should be used in conjunction with the above procedure. Do not attempt to set the switch outside the scale limits. Though the unit may be set anywhere within its operation range, for optimum performance, it is good practice to have a set point value between 25% and 75% of span.

**REPLACEMENT PARTS**

Use only factory authorised parts and procedures. The only parts normally recommended for site replacement are the microswitches. However, in some circumstances other spares kits are available. Apply for details quoting the serial number and full product code.

**WARRANTIES - SEE CONDITIONS OF SALE**

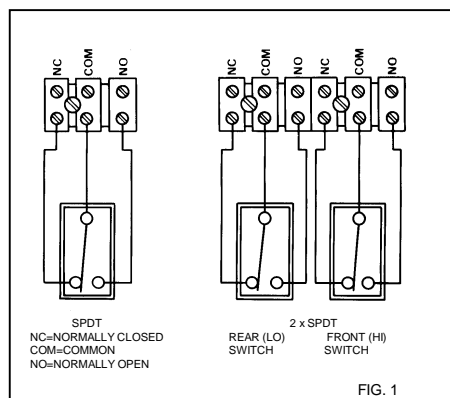
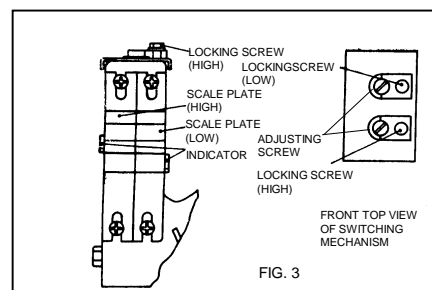
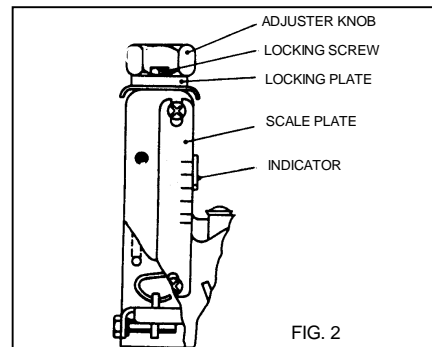
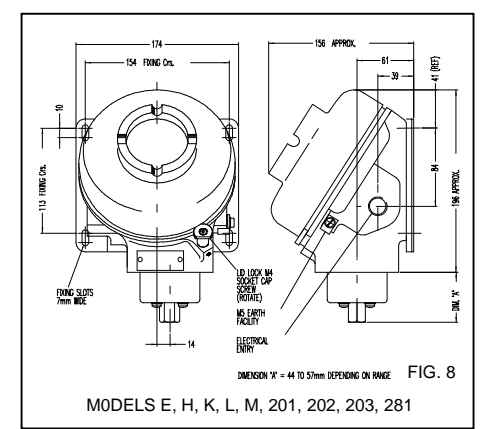
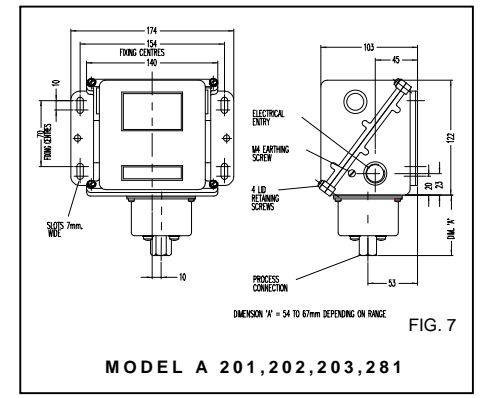
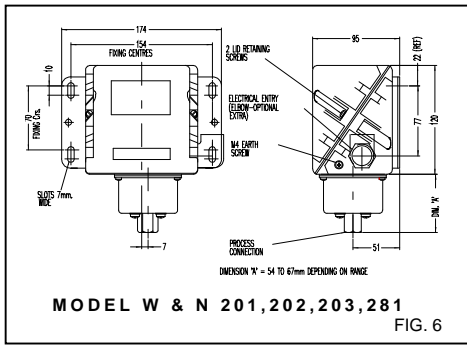
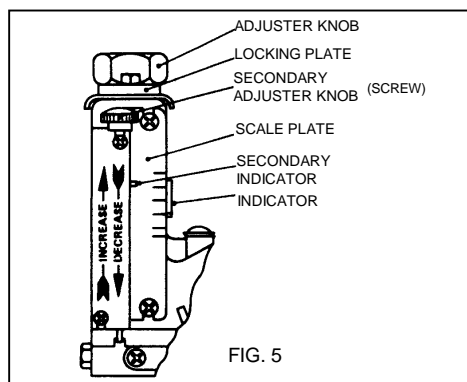
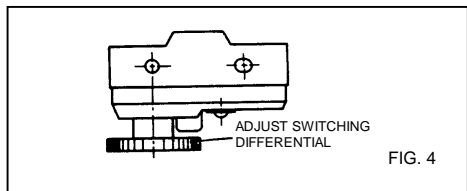
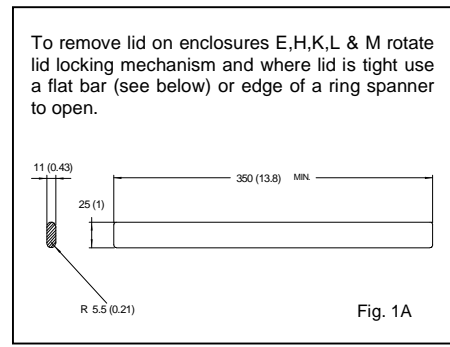

FIG.1 shows the state of electrical contacts at atmospheric pressure.

**Note:** products with ranges below atmospheric pressure have the wiring reversed between the terminal block and the microswitch(es) to achieve this state.



In the interest of development and improvement Delta Controls Ltd, reserve the right to amend without notice, details contained in this publication. No legal liability will be accepted by Delta Controls Ltd, for any errors, omissions or amendments.

**YOUR TRUSTED PARTNER IN PROCESS INSTRUMENTATION**

DELTA CONTROLS LIMITED, ISLAND FARM AVENUE, WEST MOLESEY, SURREY KT8 2UZ  
T +44 (0) 208 939 3511 F +44 (0) 208 783 1163 E sales@delta-controls.com W www.delta-controls.com

**CE** Low Voltage Directive (LVD) – 2006/95/AC. Switch products with enclosure codes 'W' and 'A' supplied CE-marked must be installed and used in accordance with the main instructions and this addendum supplied with each product. Products rated lower than 50V ac and 75 V dc are outside the scope of the LVD, and therefore, do not require CE-marking under this directive. The LVD does not apply to products with enclosure codes 'H', 'K', 'R', 'M', 'N' for use in hazardous areas. Switch products with enclosure codes 'H', 'K', 'R', 'M', 'N', are covered by the Explosive Atmospheres Directive ATEX – 94/9/EC and when CE-marked will indicate compliance with this directive alone. The following directives do not apply to switch products manufactured by Delta Controls:  
Electromagnetic Compatibility EMC – 2004/108/EC  
Machinery Safety Directive MSD – 2006/42/EC

**WIRING**

**ENCLOSURE 'W'**

**Cable Glands and adaptors** – If enclosure 'W' is supplied with a through hole of 22 mm blanked with a blind grommet. Discard the grommet and fit a suitable proprietary brass or nylon M20 cable gland with thread length of 10 mm and locknut. Fit the nylon reducer provided to the inside and a fibre washer to the outside. See diagram 1.  
Alternately, the enclosure may be supplied from the factory with a threaded adaptor ready to accept the customer's gland or conduit system.

Alternatives:

- i) a metal or nylon adaptor may be used to accommodate other sizes of gland eg NPT, or conduit system. See diagram 2.
- ii) an elbow kit may be supplied to enable the entry to be rotated axially through 90° and radially through 360°. See diagram 3.

**Earthing / grounding** – The user must make suitable local earthing arrangements, if required, to ensure that metal glands are earthed.

An earthing point is provided inside the enclosure. If this is disturbed in any way it must be reassembled correctly to be an effective earth and prevent ingress. See diagram 4. When removing the lid slacken the M4 nut first and ensure it is re tightened whenever the lid is replaced. See diagram 4.1.

**ENCLOSURE 'A'**

**Cable Glands and adaptors** – Enclosure 'A' is supplied with an M20 x 1.5 tapped hole. Use a suitable stainless steel cable gland and sealing washer. Alternately the enclosure may be supplied with a threaded adaptor fitted at the factory ready to accept the customer's gland or conduit system. See diagram 5.

**Earthing / grounding** – Bonding between the enclosure and gland / adaptor will be achieved when both parts are screwed together. An earthing point is provided inside the enclosure. If this is disturbed in any way it must be reassembled correctly to be an effective earth and prevent ingress. See diagram 4.

**EARTHING / GROUNDING OF PROCESS CONNECTION AND BACK PLATES** – All the internal dead metal work is bonded to the enclosure earthing point. Due to requirements of sealing, the process connection and back plates may be isolated from the earthing point. Do not, therefore, rely on either for earthing, instead always use the earthing point provided. If required, the process connection and back plates may be bonded locally. Never use the process connection or inlet pipe for locally grounding welding equipment unless it is separately earth bonded.

**Pollution degree** – all products are suitable for use in pollution degree 3. For extreme conditions where condensation may readily form, then sealed contacts should be used. See Table A codes 08/09, 0G/0H, H2/H3/H6.

**Electrical isolation** – These products are not suitable for electrical isolation. Always isolate circuit separately to carry out any electrical work.

**TABLE A – MICROSWITCH RATINGS**

SWITCH CODE	UL / CSA MICROSWITCH RATING (RESISTIVE) *SEE NOTE	IEC 947-5-1 / EN 60947-5-1 RATING		Designation & Utilisation Category	VA			
		U <sub>imp</sub>	U <sub>i</sub>		Make	Break		
00 & 01	5A @ 110 / 250 VAC	0.8 kV	250 V	0.6/0.3A @ 120/240 VAC	AC 14 / D300	AC	432	72
				0.22/0.1A @ 125/250 VDC	DC 13 / R300	DC	28	28
02 & 03	5A @ 110 / 250 VAC 2A @ 30 VDC	0.8 kV	250V	0.6/0.3A @ 120/240 VAC	AC 14 / D300	AC	432	72
				0.22/0.1A @ 125/250 VDC	DC 13 / R300	DC	28	28
04 & 05	1A @ 125 VAC *100mA @ 30 VDC	<b>1A @ 125 VAC RESISTIVE (IEC 1058-1/EN 61058-1)</b>						
08 & 09	*5A @ 110/250VAC 5A @ 30 VDC	0.5 kV	250V	0.6/0.3A @ 120/240 VAC	AC 14 / D300	AC	432	72
				0.22/0.1A @ 125/250 VDC	DC 13 / R300	DC	28	28
0G & 0H	*1A @ 30VAC & 30 VDC	0.5 kV	125V	0.3A @ 120 VAC	AC 14 / E150	AC	216	36
0C	5A @ 110 / 250 VAC	0.8 kV	250V	0.6/0.3A @ 120/240 VAC	AC 14 / D300	AC	432	72
0D	5A @ 110 / 250 VAC 2A @ 30 VDC	0.8 kV	250V	0.6/0.3A @ 120/240 VAC	AC 14 / D300	AC	432	72
				0.22/0.1A @ 125/250 VDC	DC 13 / R300	DC	28	28
H2 & H3 & H6	5A @ 110 / 250 VAC 2A @ 30 VDC	0.5 kV	250V	0.6/0.3A @ 120/240 VAC	AC 14 / D300	AC	432	72
				0.22/0.1A @ 125/250 VDC	DC 13 / R300	DC	28	28

The electrical rating is dependent on the microswitch fitted to the instrument. The electrical rating is defined by each approval that the microswitch complies with and is shown on the product nameplate, ie UL / CSA, or IEC. It should be noted that the switch must be used within the electrical rating specified from the approval you require. Table A lists the actual IEC ratings against the Designation & Utilisation Category marked on the nameplate. In the absence of any verification by UL / CSA the microswitch \*manufacturer's rating is specified in **bold italics**. If in doubt, seek guidance from factory.

**Declaration of Conformity**



We: Delta Controls Ltd  
Island Farm Avenue  
West Molesey  
Surrey, UK  
KT8 2UZ

As the manufacturers of the apparatus listed, declare under our sole responsibility that the products listed below:

Pressure, Pressure Difference, Temperature & Flow switches series "W" or "A":  
201, 202, 203, 281, 204, 207, 208, 209, 231, 232, 233, 234, S21, S22, S24, GR2, GR4, VM2, VM4.  
301, 303, 304, 381, 384, 306, 386, 310, 316, S31, S34, GR3, GR6.  
721, 731, 771, 722, 732, 772, 723, 733, 773, 781, 734, 774, 741, 742, 743, 744, S71, GR7.  
131.

To which this declaration relates are in conformity with the following relevant standards or parts thereof:

- EN 60947-1 :1992 Low voltage switch gear and control-gear-general rules.
- EN 60947-5-1:1992 Low voltage switch gear and control-gear-control circuit devices and switching elements.
- EN 60529: 1991 Specification for classification of degrees of protection provided by enclosures.
- EN 60950:1992 Safety of information technology equipment including electrical business equipment: section 2.5.
- BS 6134:1991 Specification for pressure and vacuum switches.

And thereby conforms to the requirements of the Low Voltage Directive 73/23/EC amended by 93/68/EEC.

Signed:

R. Harrison  
Managing Director

Original dated 22<sup>nd</sup> June 2000  
Rev. B dated 12<sup>th</sup> August 2009

